



DNA
Genetic Code of Life



Entire Genetic Code
of a Bacteria



DNA Fingerprinting



Cloning: Ethical Issues
and Future Consequences



Plants of Tomorrow

HC70A, SAS70A, & PLSS059 Winter 2018 Genetic Engineering in Medicine, Agriculture, and Law

Professors Bob Goldberg, John Harada,
& Channapatna Prakash

Lecture 3 What Are Genes & How Do They Work: Part One

UCLA

TUSKEGEE
UNIVERSITY

UC DAVIS
UNIVERSITY OF CALIFORNIA



DNA
Genetic Code of Life



Entire Genetic Code
of a Bacteria

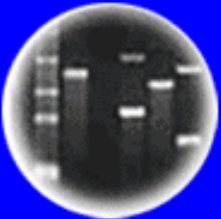

DNA Fingerprinting



Cloning: Ethical Issues
and Future Consequences



Plants of Tomorrow

THEMES

Gene Structure & Function

Part One (Text Chapter 2)

- What is the Function of a Gene?
- What are the Properties of Genes?
- How Was DNA Discovered?
- How Do We Know That the Nucleus Controls Cellular Functions?
- What is the Evidence That DNA is the Genetic Material (Griffith and Avery Experiments)?
- Is Transformation Universal?
- Can RNA Be the Genetic Material?
- What is the Structure of DNA?
- What is the Structure of a Chromosome?
- What is the Colinearity Between Genes & Proteins (how does DNA→protein)?
- How Do We Know That Genes Function Independently of One Another?
- What is the Anatomy of a Gene?
- How Do Switches Work to Control Gene Activity?
- What Are the Possibilities For Manipulating Genes in the Future?



Understanding Genetic Engineering

*Requires a Basic Understanding of Genes
And How They Work*

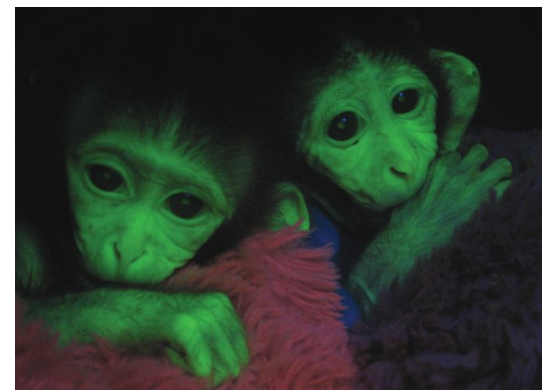

Understanding the Properties of Genes & How Genes Can Specify Traits Is the "Key" to Understanding Genetic Engineering by *Either Classical or Molecular Approaches!!*

Can Intervene in This Process in Cells

Genetic Engineering Is not "Hocus Pocus." It Uses "Natural" Cell Processes!!!!

What's a GMO?

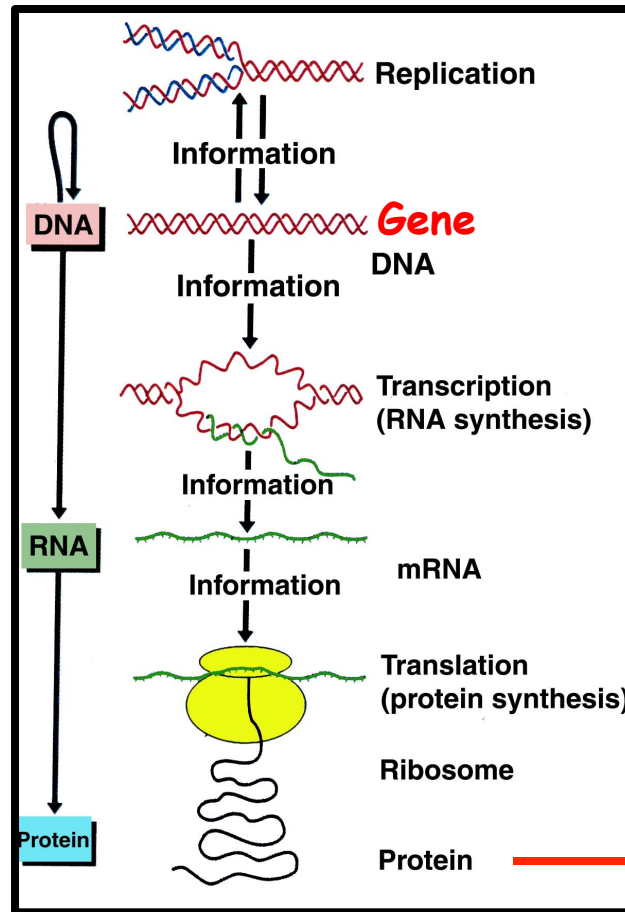

All Organisms Use The SAME Processes And "RULES" to Generate Traits!! And The SAME Molecules & Chemistry!!

Coat Color Trait





DNA
Genetic Code of Life



Entire Genetic Code
of a Bacteria



DNA Fingerprinting



Cloning: Ethical Issues
and Future Consequences



Plants of Tomorrow

WHAT ARE THE PROPERTIES OF A GENE?

1. Replication
2. Stability (Mutations)
3. Universality
 - a) All Cells
 - b) All Organisms
4. Direct Cell Function/Phenotype

• How Can These Properties Be Tested Experimentally?

• What Predictions Follow From These Properties?

If DNA is the Genetic Material, THEN What.....?

How Was DNA Shown to be the
Genetic Material?



DNA
Genetic Code of Life



Entire Genetic Code
of a Bacteria

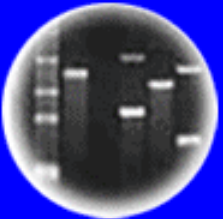

DNA Fingerprinting



Cloning: Ethical Issues
and Future Consequences



Plants of Tomorrow

Frederick Miescher Discovered DNA in the Nuclei of White Blood Cells in 1869

150 Years Ago

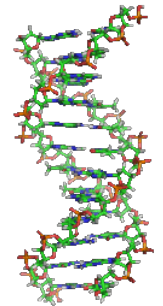
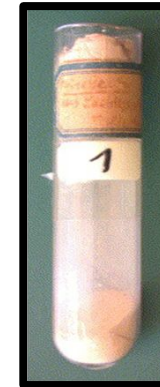
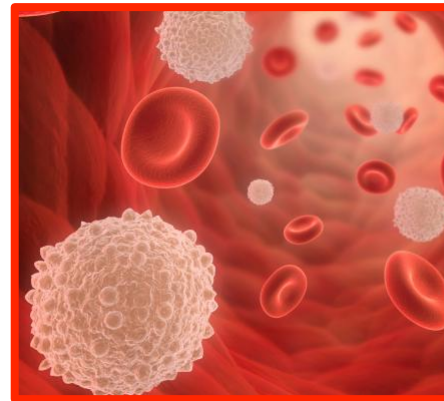
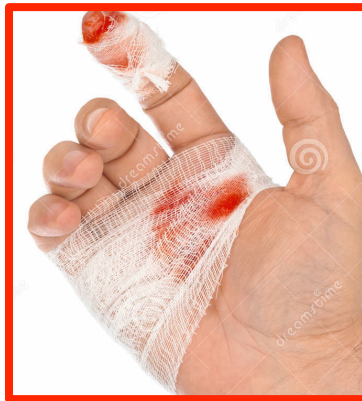

***But.... The Function of DNA was Not Understood Until
75 years Later in 1944!!!***

How Was It Demonstrated That the Nucleus Controls All Biological Functions?

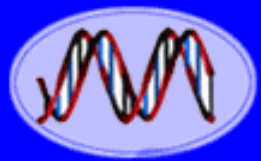

DNA
Genetic Code of Life



Entire Genetic Code
of a Bacteria

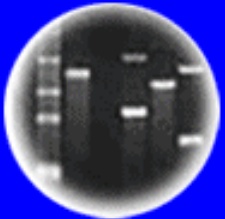

DNA Fingerprinting



Cloning: Ethical Issues
and Future Consequences



Plants of Tomorrow



Acetabularia is a Single Cell Green Algae That Has a Cap and Foot Where the Nucleus Resides. Cap Morphology Varies With the Algal Species

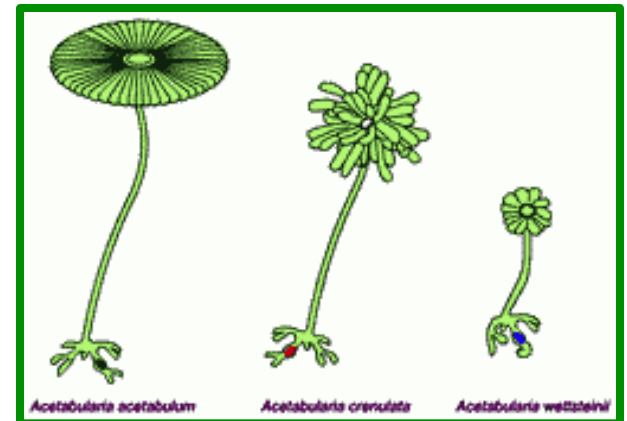



DNA
Genetic Code of Life



Entire Genetic Code
of a Bacteria

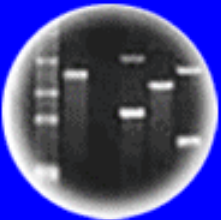

DNA Fingerprinting



Cloning: Ethical Issues
and Future Consequences



Plants of Tomorrow

Hammerling's Transplant Experiment Demonstrated That the Nucleus Controls Cap Morphology and Developmental Functions

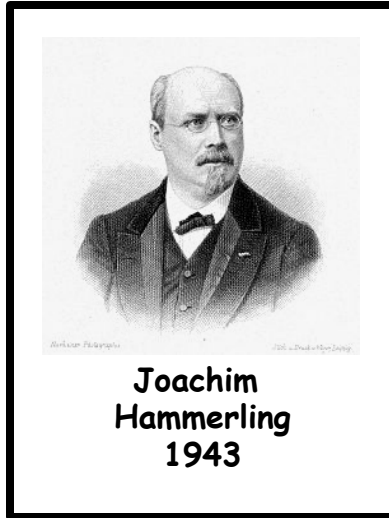

Joachim
Hammerling
1943

A Year Later - in
1944 -
DNA Was Shown
to Be the Genetic
Material By Avery
and His Colleagues

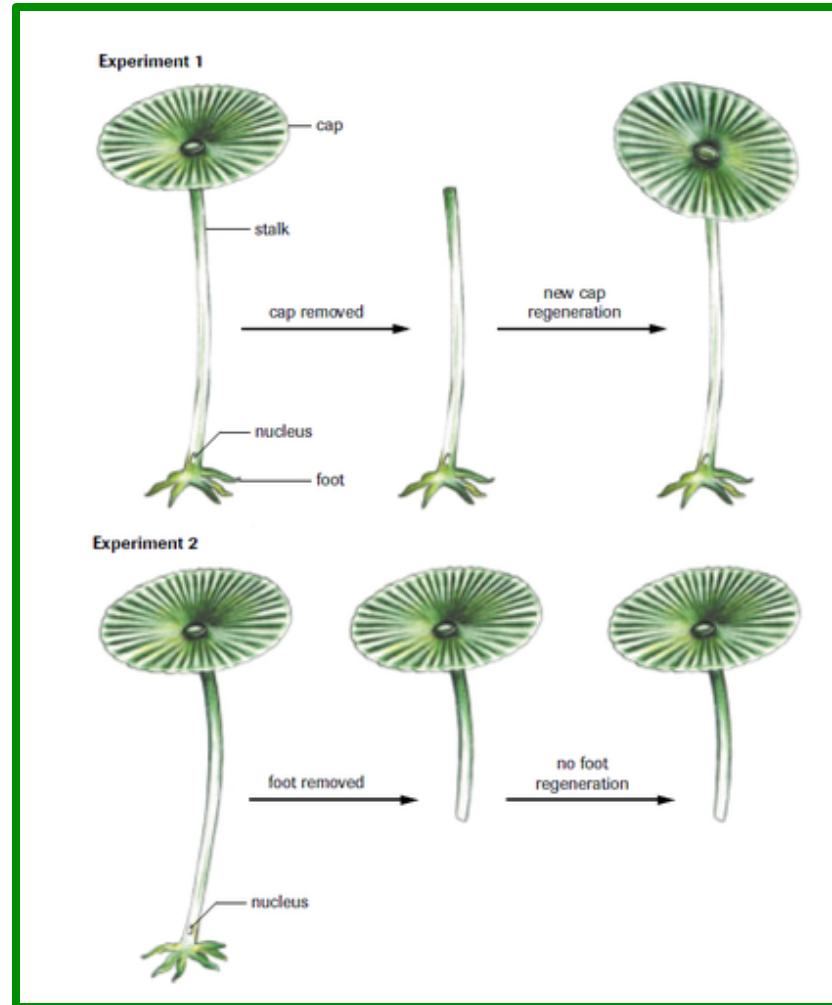

And..... Demonstrated That There Must Be a "Diffusible"
Substances Traveling From the Nucleus to Site of Cap
To Control **Cap Morphology Formation**



DNA
Genetic Code of Life



Entire Genetic Code
of a Bacteria

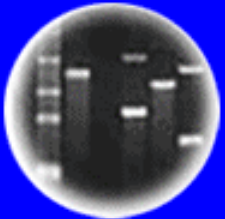

DNA Fingerprinting



Cloning: Ethical Issues
and Future Consequences



Plants of Tomorrow

How Was DNA Shown to be the Genetic Material?

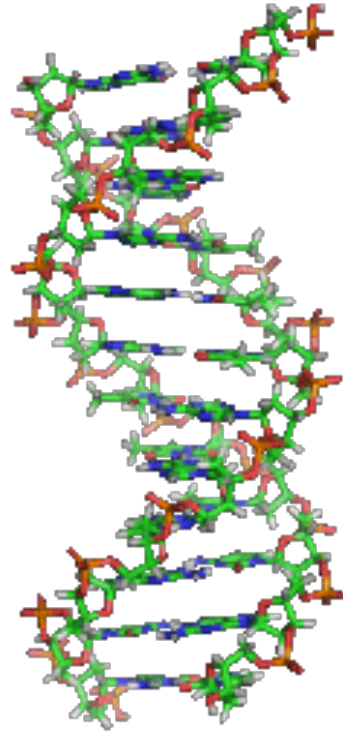

*And.....is it Possible That RNA Can Be the
Genetic Material As Well?*

Evidence That DNA Is the Genetic Material Starts With Pneumonia

PNEUMONIA KILLS 990 IN CITY SINCE JAN. 1; Forty-Eight Die in Twenty-Four Hours, Four Fewer Than on Previous Day. 387 INFLUENZA CASES Six More Deaths Reported, but Copeland Sees Chief Danger in First-Named Disease.
January 29, 1922 - New York City

Spanish Flu (viral) Was also "Killer" at This Time!

INFLUENZA
FREQUENTLY COMPLICATED WITH
PNEUMONIA
IS PREVALENT AT THIS TIME THROUGHOUT AMERICA.
THIS THEATRE IS CO-OPERATING WITH THE DEPARTMENT OF HEALTH.
YOU MUST DO THE SAME
IF YOU HAVE A COLD AND ARE COUGHING AND SNEEZING, DO NOT ENTER THIS THEATRE
GO HOME AND GO TO BED UNTIL YOU ARE WELL.
Coughing, Sneezing or Spitting Will Not Be Permitted In The Theatre. In case you must cough or sneeze, do so in your own handkerchief, and if the coughing or sneezing persists leave the theatre at once.
This Theatre has agreed to cooperate with the Department Of Health in disseminating the truth about Influenza, and thus serve a great educational purpose.
HELP US TO KEEP CHICAGO THE HEALTHIEST CITY IN THE WORLD
JOHN DILL ROBERTSON
COMMISSIONER OF HEALTH

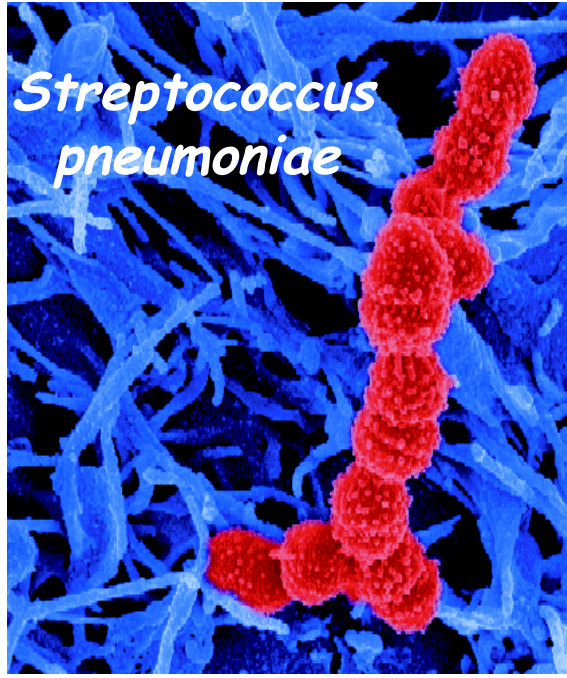

Spanish Influenza has endangered the prosecution of the WAR in Europe.
There are 1500 cases in the Navy Yard
30 deaths have already resulted
SPITTING SPREADS SPANISH INFLUENZA DONT SPIT

Epidemic Closing
Order Is Sweeping
The State Board of Health order, closing schools, theatres, churches, saloons, etc., in an effort to prevent a further spread of the Spanish Influenza epidemic, is a sweeping one. All clubs must close, including bowling alleys and pool rooms. No society, club or organization meeting can be held, not even at homes.

Spanish Flu Killed 50-100 million people world-wide from 1918 to 1920 - Most From Secondary Bacterial Infections

Frederick Griffith & The Transforming Principle

The First Genetic Engineering Experiment (unintentional!)



Frederick Griffith

1879-1941

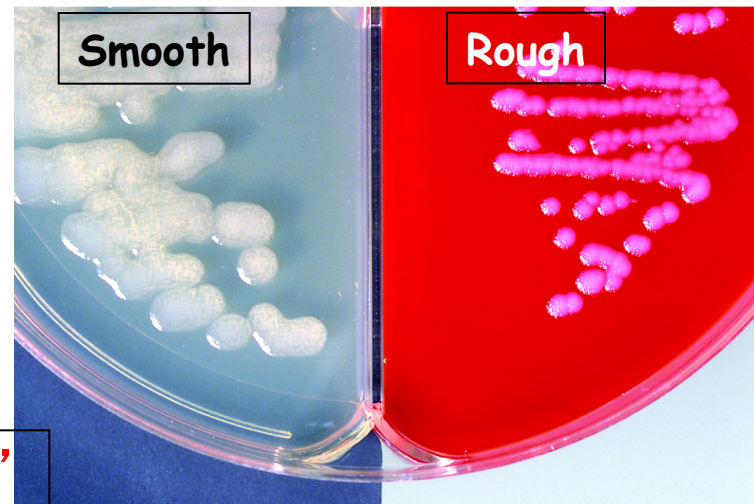
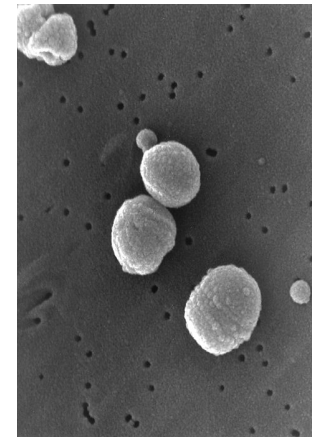
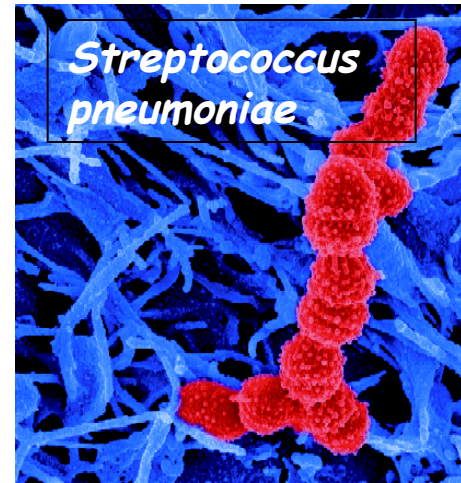
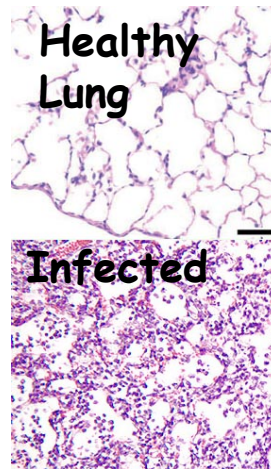

Note:
Different
Strains of
*Streptococcus
Pneumoniae*
Exist in
Nature

Type I, II,
etc.

Invented the Word "Transformation"
Not Understood For Another 50 Years

The Griffith Experiment With Smooth and Rough Pneumonia Bacteria

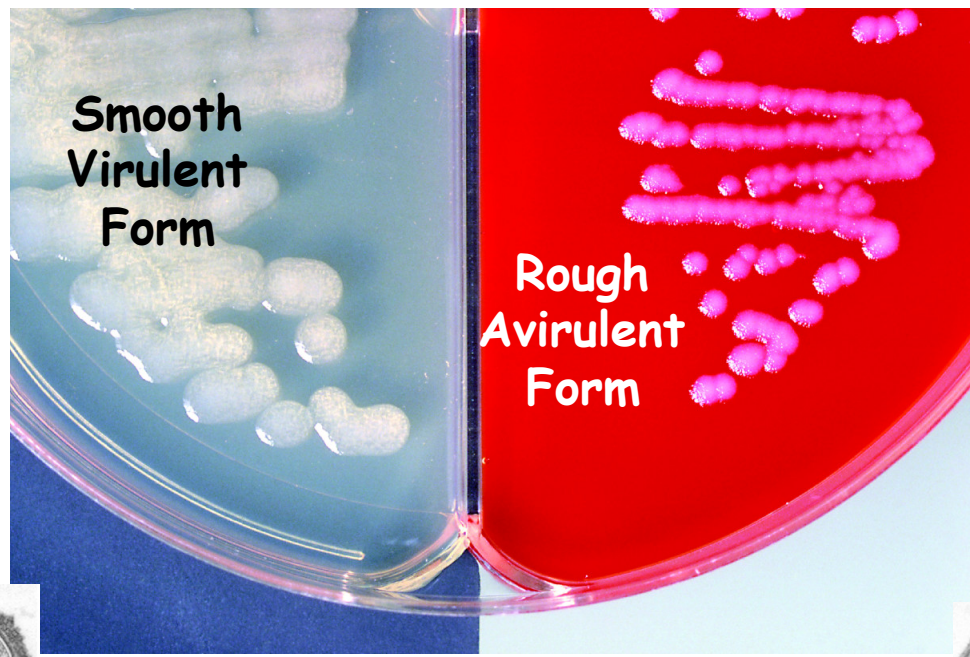

Spontaneous Mutations
Always Retain
the Strain Type

SI to RI

Never SI to RII

As Too Many
Genes Are
Involved!

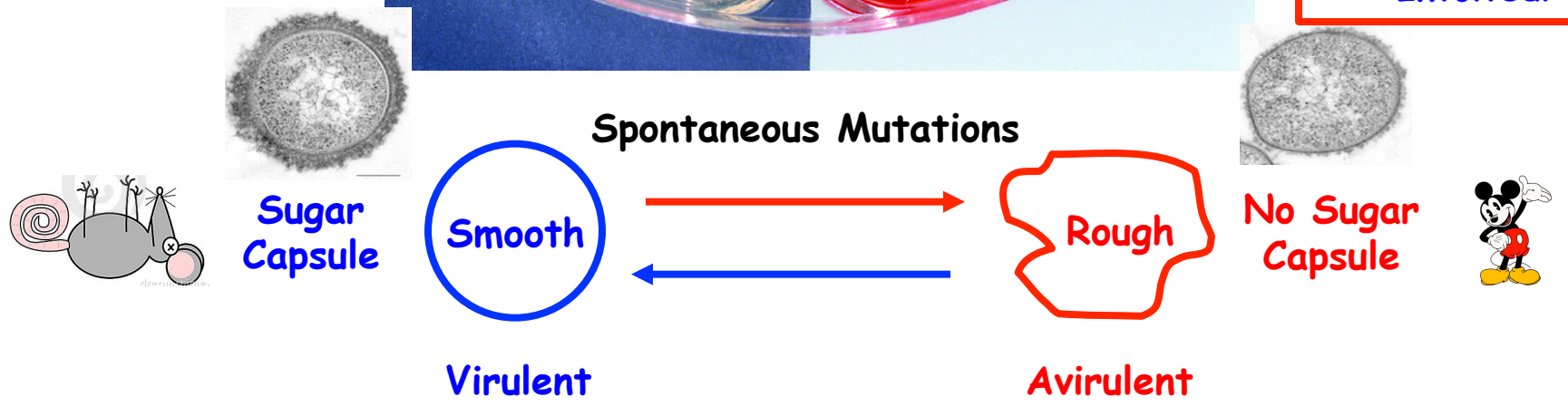

Streptococcus pneumoniae

Flash Forward to the 21st Century

Capsule Biosynthesis

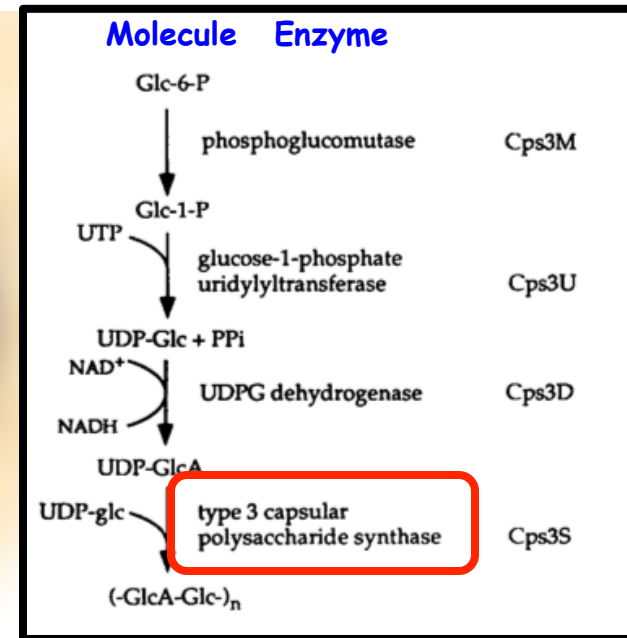
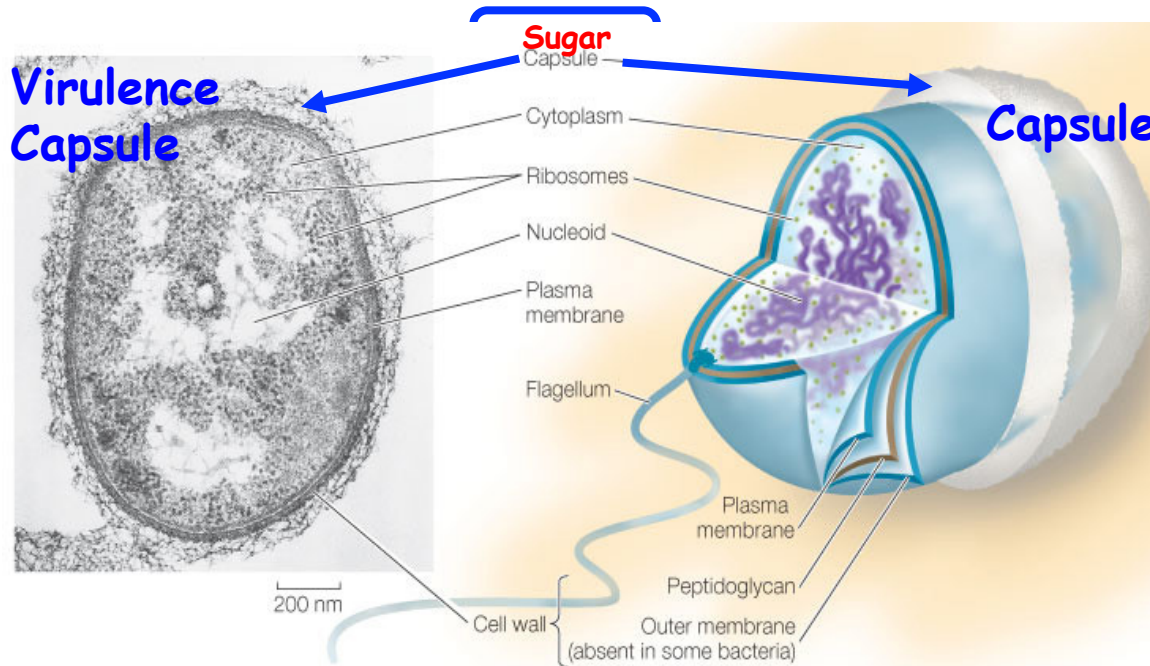

J. Exp. Med. 181, 973, 1995

Streptococcus Strains Depend On the Sugar Type in the Capsule - Which is a Product Of MANY Genes!

The Sugar Capsule Protects the Bacteria From Mammalian Host Antibodies
Capsule = Virulence No Capsule = Avirulence

Streptococcus pneumoniae Genome Has Been Sequenced!

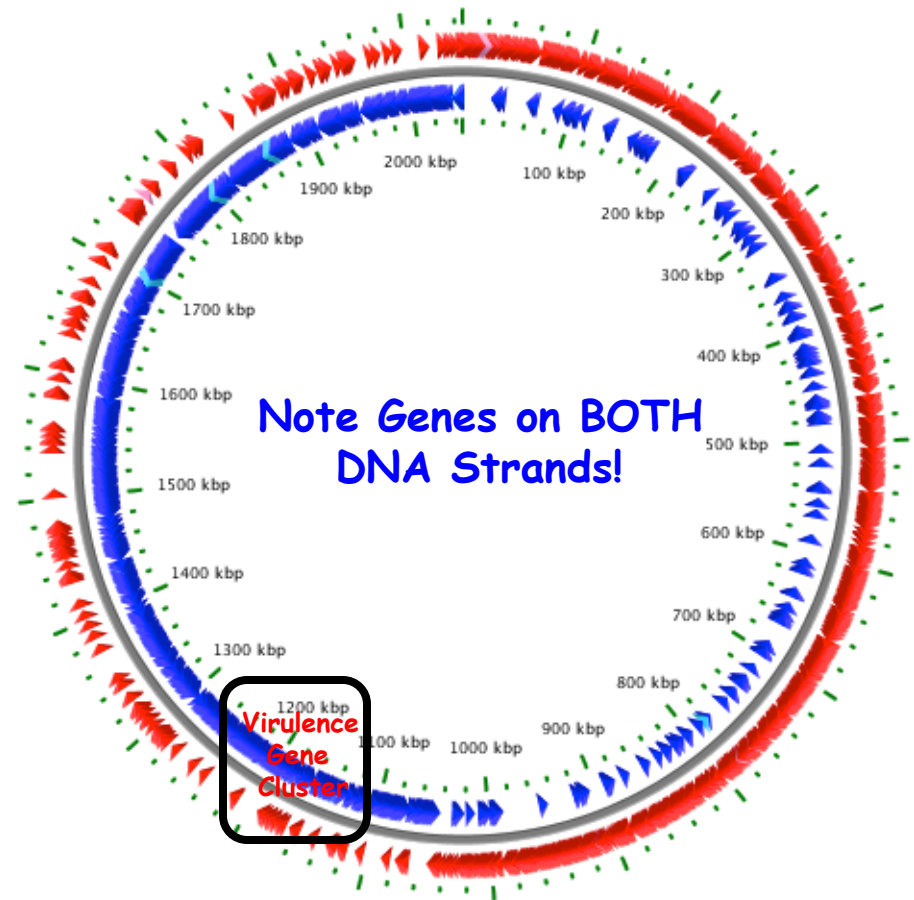

2,160,837 bp and 2,236 Genes
At Least 13 Genes Specify Capsule Formation
What Happens If One of These Genes Is Mutated?

Correlation of *Streptococcus* Genes With Biological Functions (i.e., Genome Annotation)

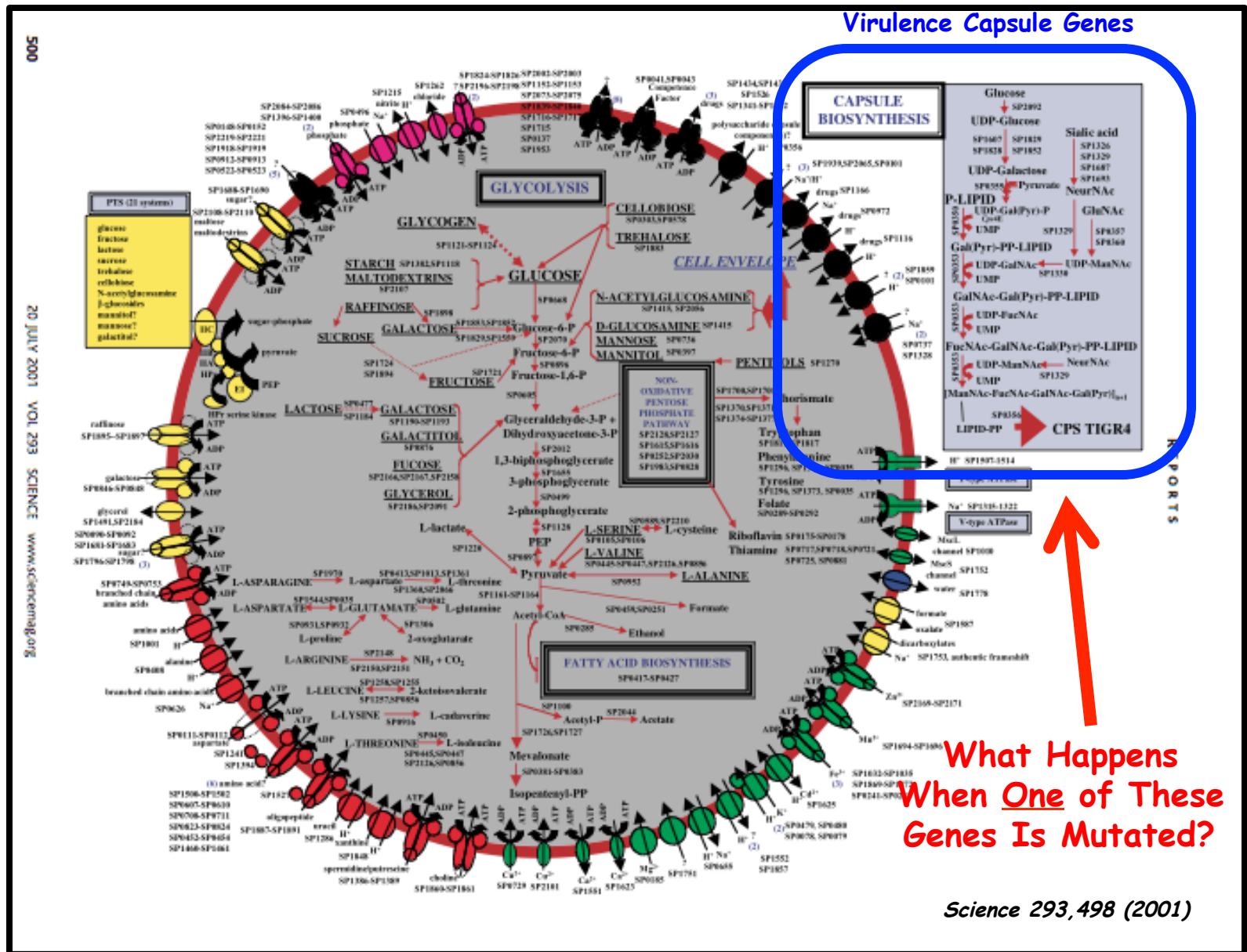

The Griffith Experiment (1928)

EXPERIMENT

HYPOTHESIS: Material in dead bacterial cells can genetically transform living bacterial cells.

MIX LIVE ROUGH & DEAD SMOOTH CELLS

CONTROLS

Kill the virulent S strain bacteria by heating.

BOILING KILLS SMOOTH CELLS

Mix dead S strain cells with living, nonvirulent R strain bacteria.

METHOD

1



2

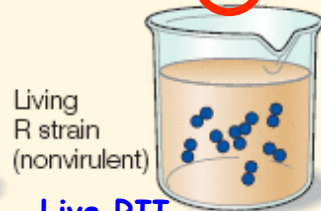

3

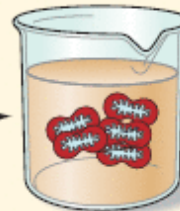
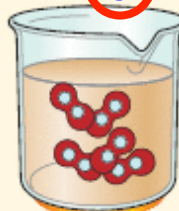

4

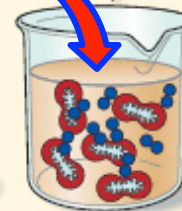
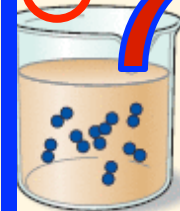

Live RII + Dead SI



RESULTS

Mouse dies

Living S strain cells found in heart

Mouse healthy

No bacterial cells found in heart

Mouse healthy

No bacterial cells found in heart

Live SI!!!!!!

Mouse dies

Living S strain cells found in heart

CONCLUSION: A chemical substance from one cell is capable of genetically transforming another cell.

MOUSE DIES - SMOOTH CELLS FOUND IN HEART

LIVE Rough Cells **TRANSFORMED** by **DEAD** Smooth Cells!!!
HOW? What Was the Transforming Principle? Hypothesis?

Griffith, 1928, J. of Hygiene, 28 (2), 113-157

VOLUME XXVII

JANUARY, 1928

No. 2

THE SIGNIFICANCE OF PNEUMOCOCCAL TYPES.

By FRED. GRIFFITH, M.B.

(A Medical Officer of the Ministry of Health.)

(From the Ministry's Pathological Laboratory.)

Inoculation experiments with heated virulent Type I culture and attenuated R strains of Types I and II.

Conversion of R Type II into S Type I. In the experiment in Table VII two out of eight mice injected with heated virulent Type I culture together with an attenuated R culture derived from Type II died of pneumococcal septicaemia and yielded pure S colonies of Type I from the blood; plates from the lesions at the seat of inoculation showed a mixture of R and S colonies.

Killed S pneumococci
Type I heated 2 hours at 60° C. Dose = deposit of 50 c.c. of broth culture

As above

As above

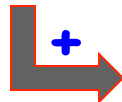

Table VII.

Living R pneumococci	No. of mouse	Result	Type of culture obtained from mouse
None	641	Killed 5 days	None
"	642	" 6 "	"
"	643	" 6 "	"
"	644	" 6 "	"
R 4, Type II. Dose = 0.25 c.c. of blood broth culture	645	Died 3 days	S colonies, Type I
	646	Killed 5 "	R cols. from local lesion
	647	" 6 "	" "
	648	" 6 "	" "
R 4, Type II, grown in the heated Type I deposit. Dose = 0.36 c.c.	649	Killed 5 days	R cols. from local lesion
	650	Died 4 "	S colonies, Type I
	651	Killed 6 "	None
	652	" 6 "	One R colony

Note: R Strain II Transformed into Smooth Strain I

What Hypothesis Explains This Transformation?

What Was The Transforming Principle? Experiments of Avery, McCleod, & McCarty Fast Forward to the 1940s!

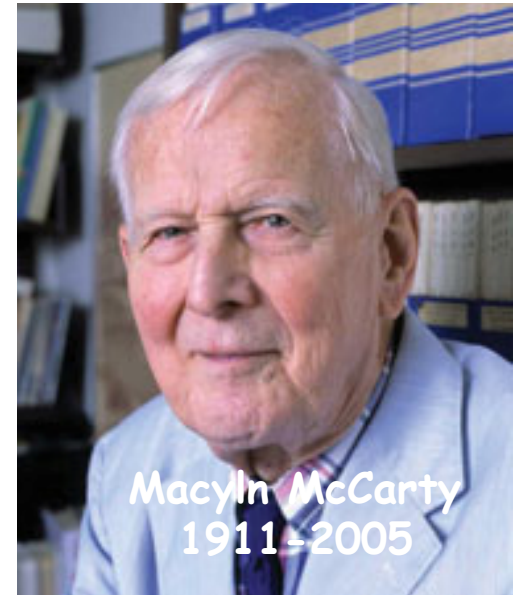
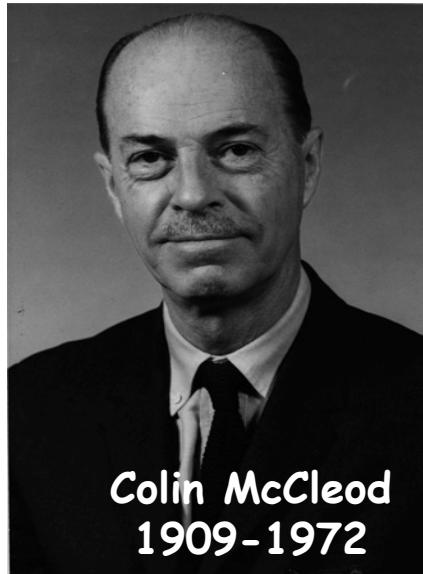

DNA is the Genetic Material!

One of the Major Reasons Watson and Crick
Considered DNA As the Genetic Material
In Order to Solve DNA Structure



DNA
Genetic Code of Life



Entire Genetic Code
of a Bacteria



DNA Fingerprinting



Cloning: Ethical Issues
and Future Consequences



Plants of Tomorrow

STUDIES ON THE CHEMICAL
NATURE OF THE SUBSTANCE
INDUCING TRANSFORMATION
OF PNEUMOCOCCAL TYPES

OSWALD T. AVERY, COLIN M. MacLEOD, AND
MACLYN McCARTY

J. Of Experimental Medicine, 79 (2), 137-158 (1944)

STUDIES ON THE CHEMICAL NATURE OF THE SUBSTANCE
INDUCING TRANSFORMATION OF PNEUMOCOCCAL TYPES

INDUCTION OF TRANSFORMATION BY A DESOXYRIBONUCLEIC ACID FRACTION
ISOLATED FROM PNEUMOCOCCUS TYPE III

By OSWALD T. AVERY, M.D., COLIN M. MacLEOD, M.D., AND
MACLYN McCARTY,* M.D.

Avery et al. Questions?

1. Does the *Transforming Principle* Come From the Mouse or Bacteria?
2. If From the Bacteria -- What Substance?
3. How Devise Techniques to Determine What the *Transforming Principle* is
 - a) Transformation in Test Tube
 - b) Isolation of Macromolecules
 - c) Isolation of Enzymes (e.g., DNase, RNase)

Design Experiments To Show!!!

Does the Transforming Principle Come From the *Mouse* or *Bacteria*?

Mix in Test Tube

Look at Morphology on Agar Plate

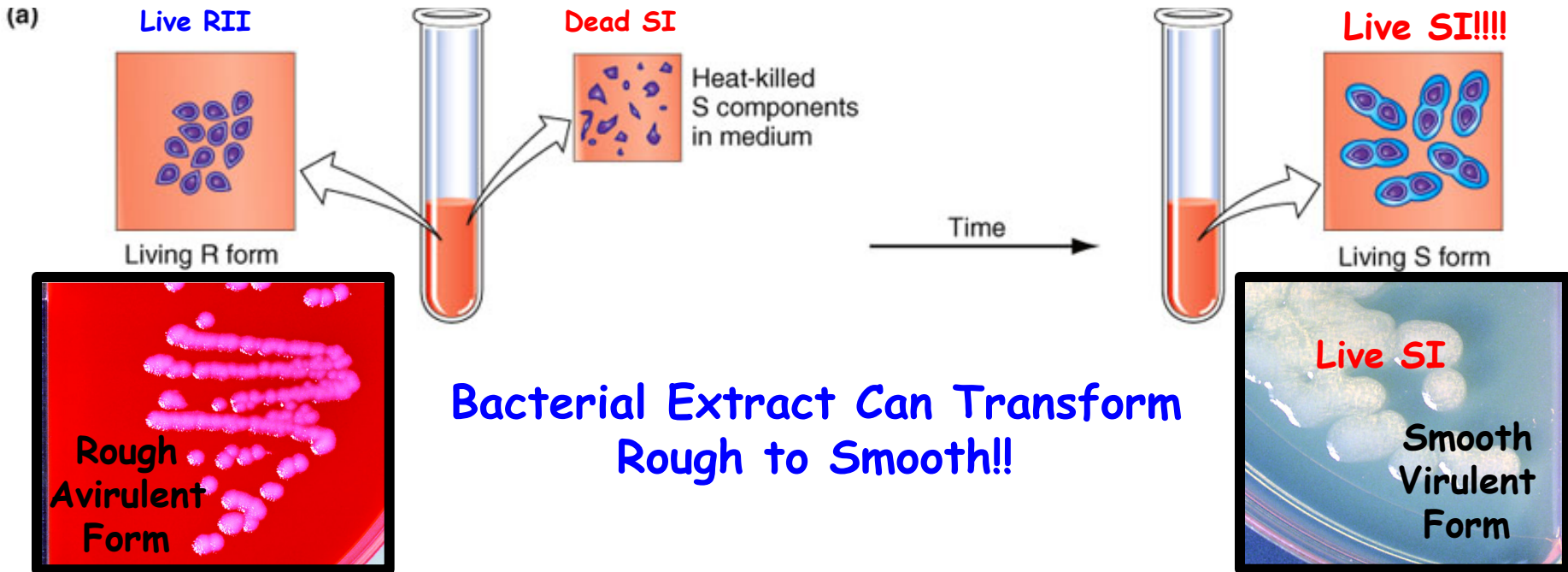

Hypothesis? Predictions? Experiment?

What Are the Major Chemical Components of a Bacterial Cell?

What Could Be the Transforming Principle?

Table 2-2 The Approximate Chemical Composition of a Bacterial Cell

	PERCENT OF TOTAL CELL WEIGHT	NUMBER OF TYPES OF EACH MOLECULE
Water	70	1
Inorganic ions	1	20
Sugars and precursors	1	250
Amino acids and precursors	0.4	100
Nucleotides and precursors	0.4	100
Fatty acids and precursors	1	50
Other small molecules	0.2	~300
Macromolecules (proteins, nucleic acids, and polysaccharides)	26	~3000

1. What is Predicted if DNA is the Genetic Material?

2. How Test Hypothesis?

Macromolecules

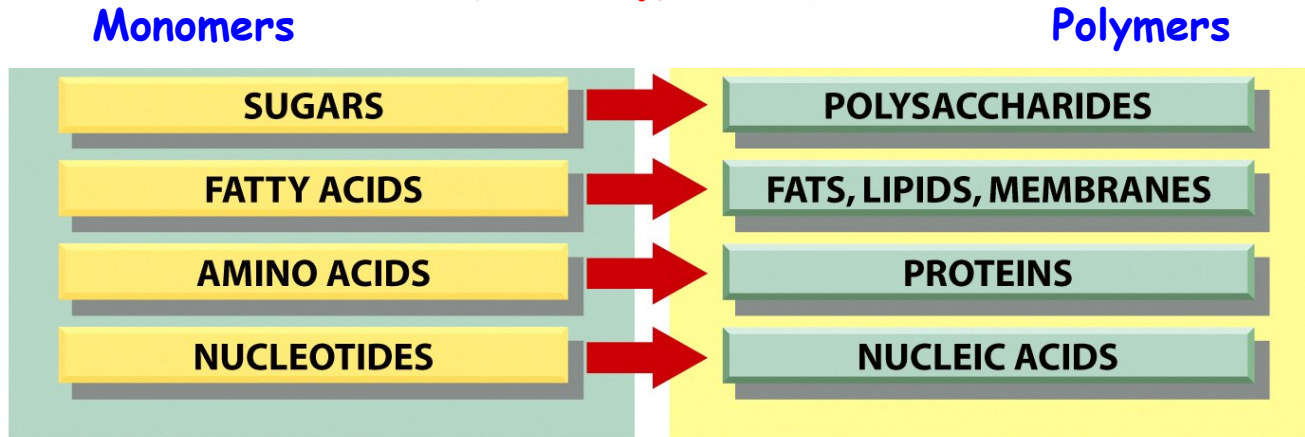

Testing Macromolecules For Transforming Activity

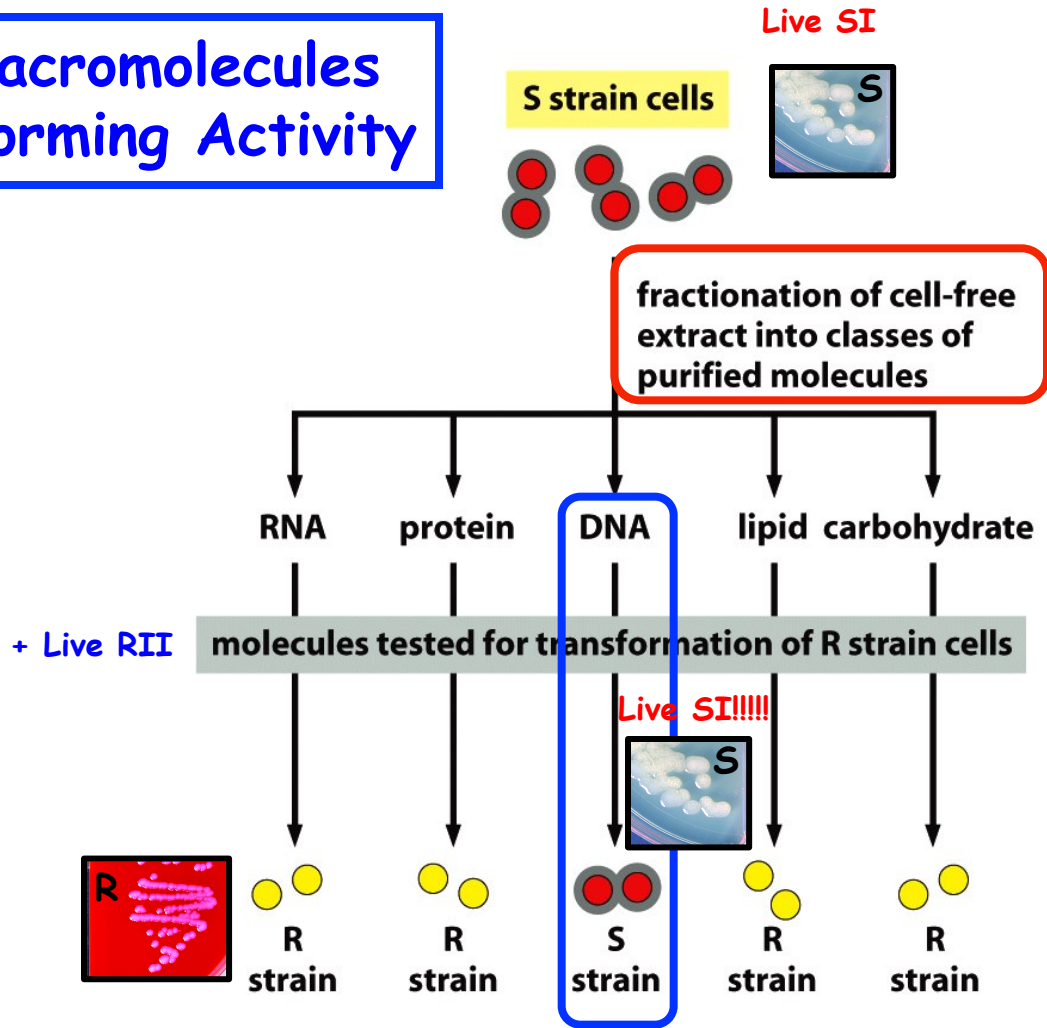

CONCLUSION: The molecule that carries the heritable information is DNA.

First Transformation Experiment With Purified Molecules!!

The Avery et al. Experiment Showed Conclusively
that DNA is the Genetic Material?

a. yes

b. no

THE Critical Experiment by Avery et al. Showing That DNA IS THE Genetic Material

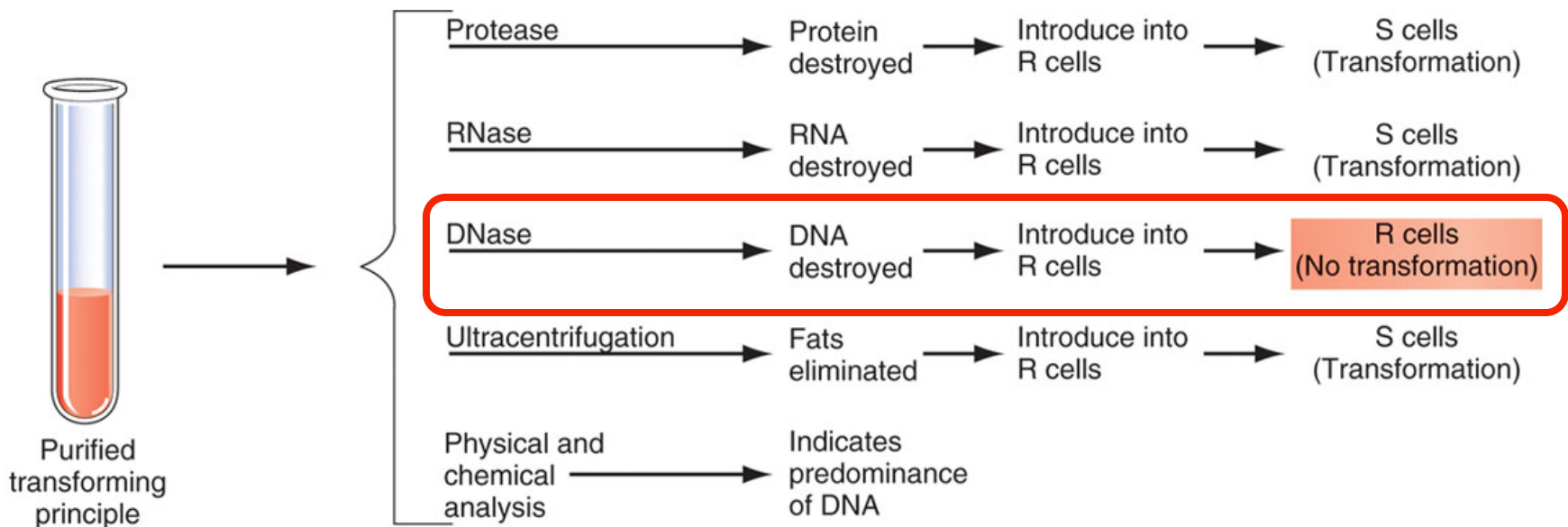

When DNase Destroyed DNA There Was No Transformation & Only Rough Cells Were Found in the Culture

If Smooth DNA Not Present, Rough Cells Cannot Be Transformed Into Smooth Cells!

How Did Avery et al. Experiments Verify the Hypothesis That DNA is the Genetic Material?

<u>Predictions</u>	<u>Results</u>
Replication	Yes
Phenotype	Yes
Stable	Yes

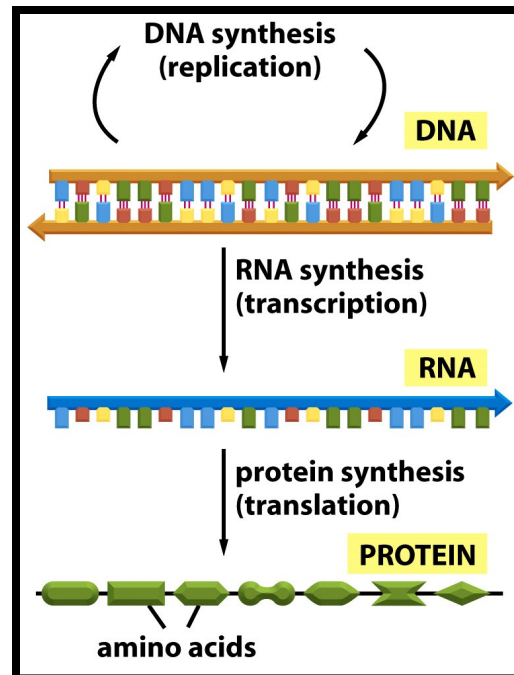

DNA Satisfies Criteria For Being the Genetic Material

- Replicates
- Directs Production of Strain/Capsule Type
- In All Progenitor Cells

Cell Processes

1. SI DNA Taken Up By RII-Cells & Incorporated Into Chromosomes
2. SI Gene Transcribed Into SI mRNA
3. SI mRNA Translated Into Smooth I Protein
4. Smooth I Protein Helps Construct Sugar Capsule and Protects Bacteria From Antibodies
∴ Cells Virulent

Transformation is a Basic Genetic Engineering Process Today!
Transformation=Ability of Cell Phenotype To Be Changed by DNA!

Can Bacteria Be Transformed With Other Genes and Traits?

Cohen & Boyer Experiment That “Invented” Genetic Engineering

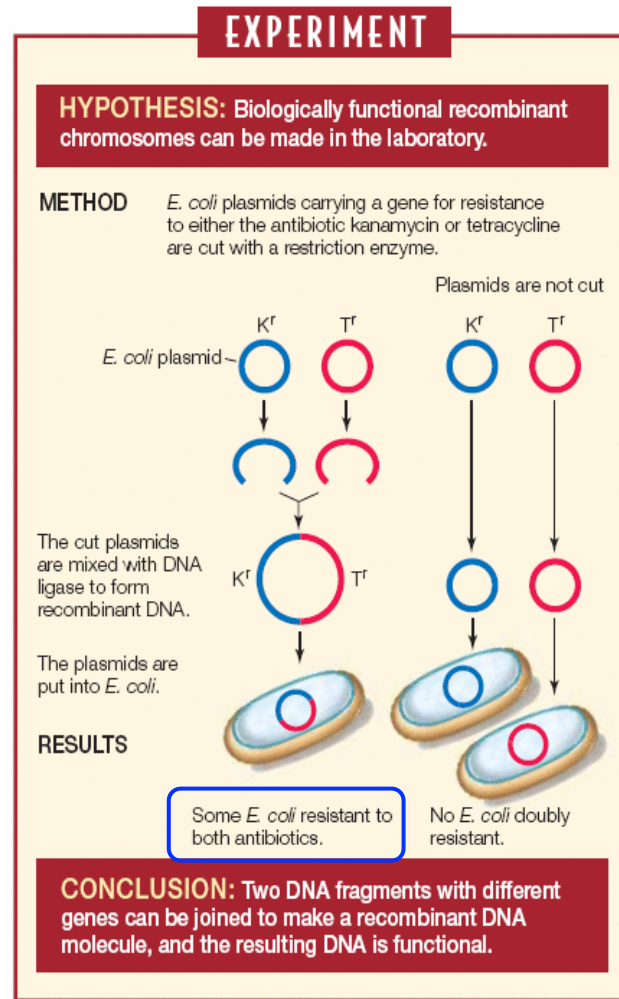

Because the Transforming Principle is DNA
Any Gene Can Be Transformed (e.g., Antibiotic^S to Antibiotic^R)

All Organisms Can Be Transformed!!

Genetic Engineering Has Come a Long Way Since Griffiths Experiments in 1928!!

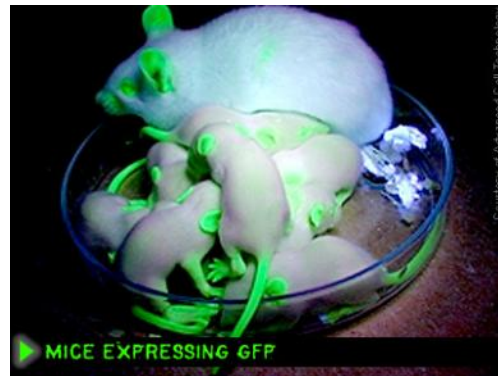
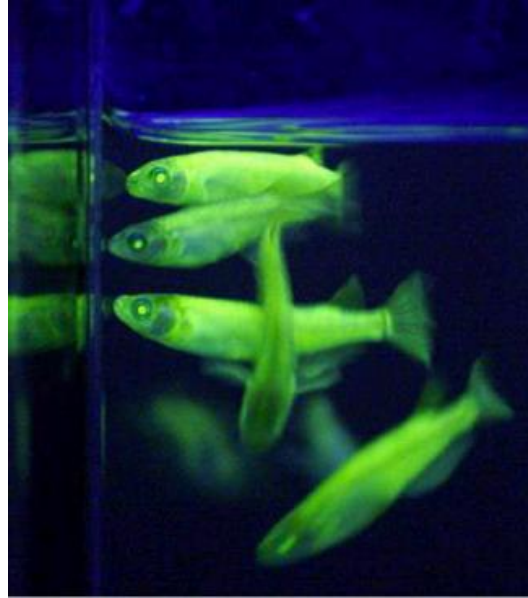
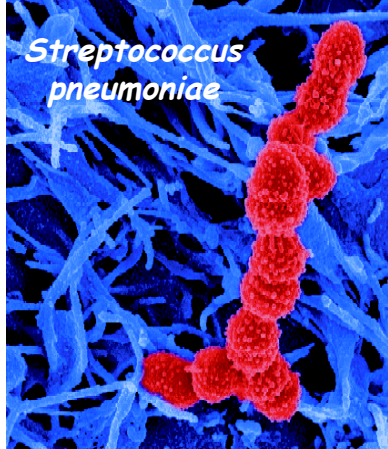

Genetic Engineering/Transformation Involves Incorporating Engineered DNA or Genes Into the Chromosomes of Different Organisms

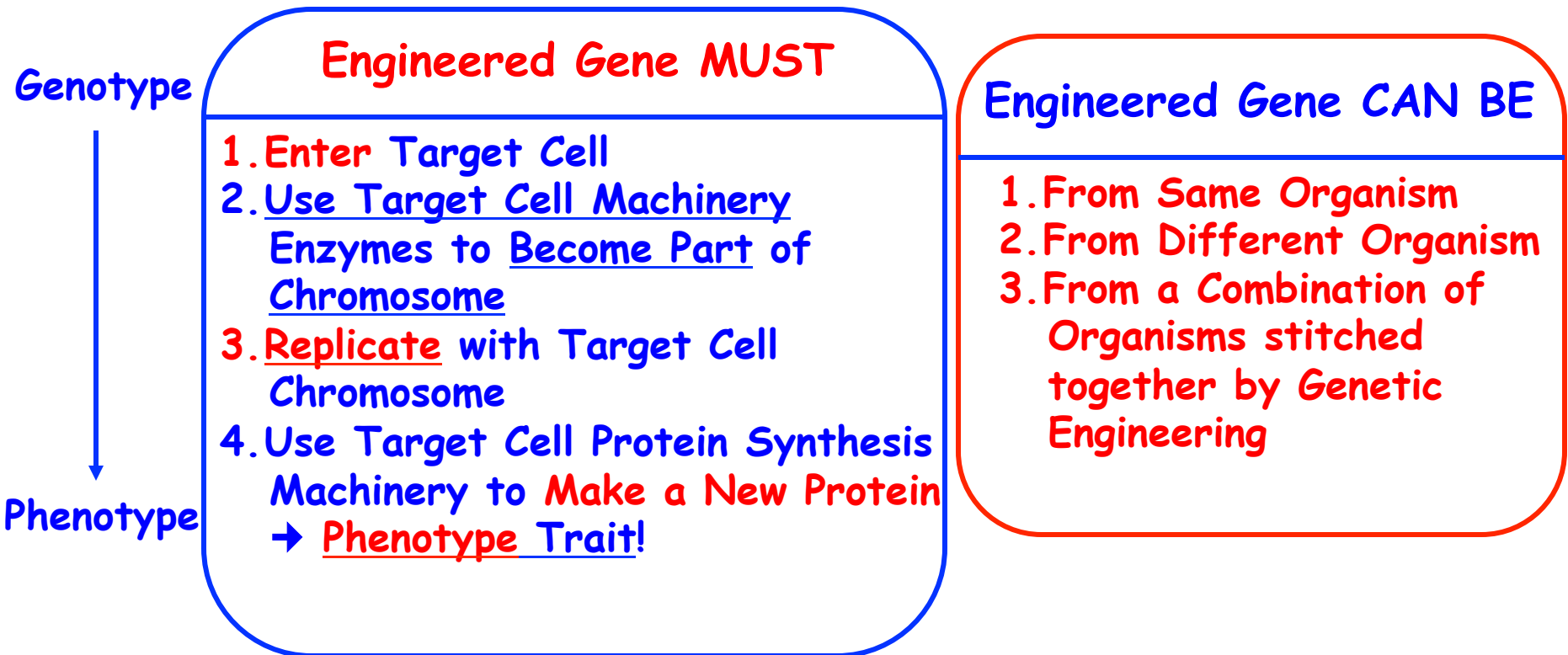

Gene Engineering Shows that Gene Processes Are Universal!!!

Just Like The GloGene Experiments!!!

Transformation of Cells With DNA Uses Normal Cellular Processes To Produce a New Phenotype

*Can Intervene
in This Process in
Cells*

*Genetic Engineering
Is not "Hocus Pocus."
It Uses "Natural"
Cell Processes!!!!*

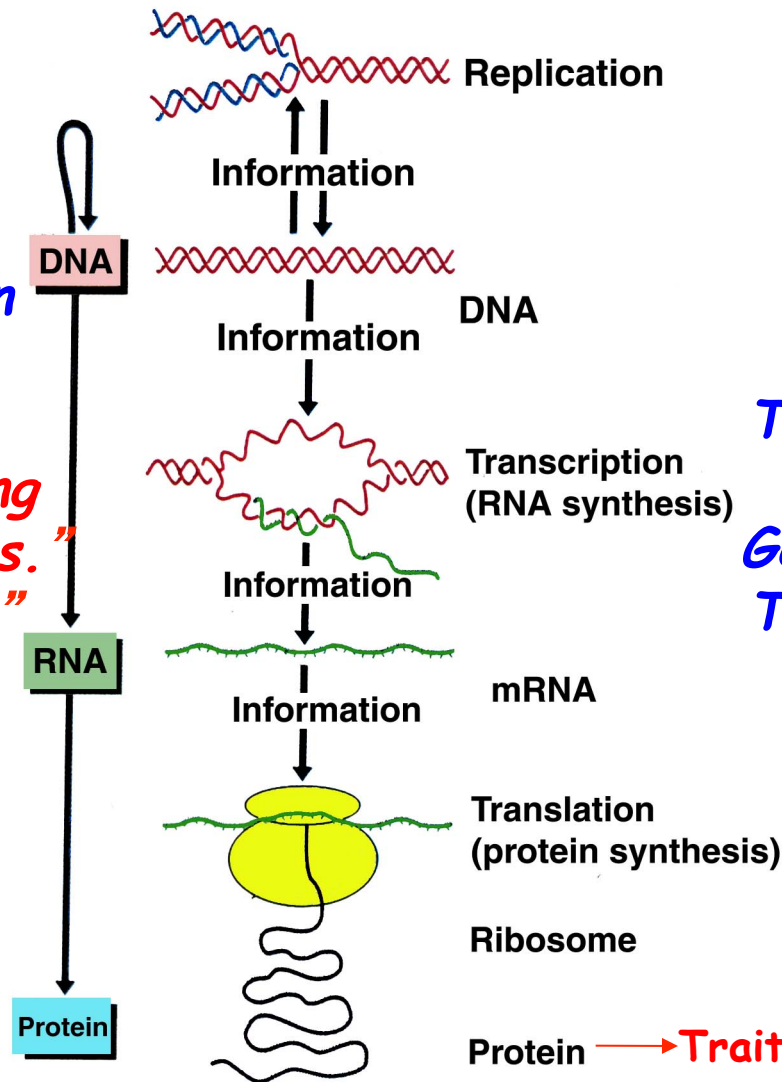

*All Organisms Use
The SAME Processes
And "RULES" to
Generate Traits!! And
The SAME Molecules
& Chemistry!!*

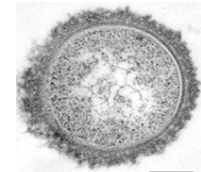

Protein → Trait (e.g., Smooth Bacteria)



DNA
Genetic Code of Life



Entire Genetic Code
of a Bacteria

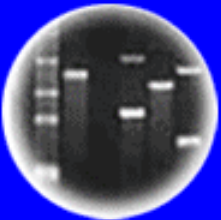

DNA Fingerprinting



Cloning: Ethical Issues
and Future Consequences



Plants of Tomorrow

What is the Evidence For RNA Being the Genetic Material?

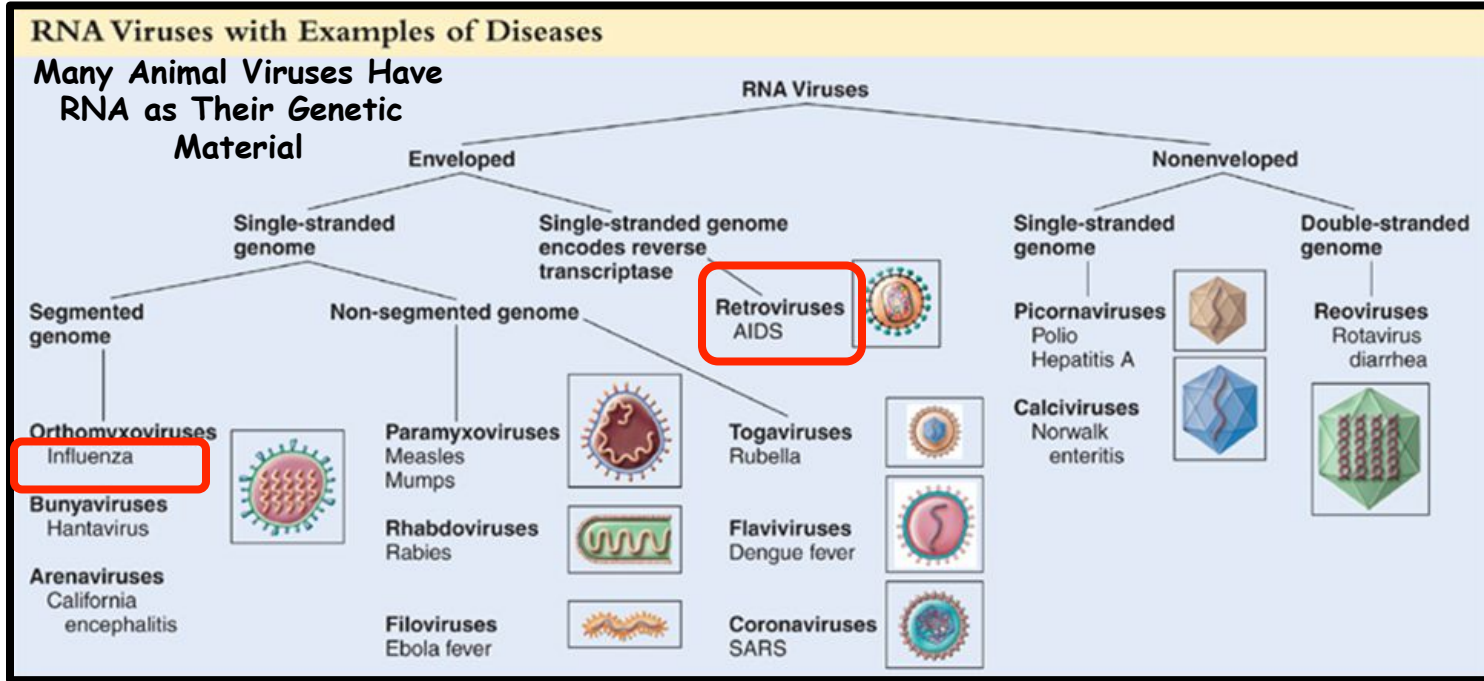

**Many Plant Viruses Also Have RNA Genomes
And Are Devastating Crop Pathogens!!**

Tobacco Mosaic Virus

RNA nucleotides

proteins

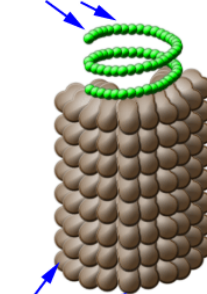



DNA
Genetic Code of Life



Entire Genetic Code
of a Bacteria

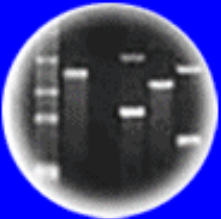

DNA Fingerprinting



Cloning: Ethical Issues
and Future Consequences



Plants of Tomorrow

The Papaya Ringspot Virus Almost Wiped Out the Hawaiian Papaya Industry

*But... Was Saved By Genetic Engineering For Viral
Resistance!!!*

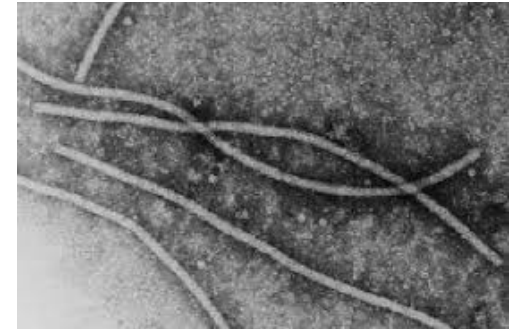

UC Statewide IPM Project
© 2000 Regents, University of California



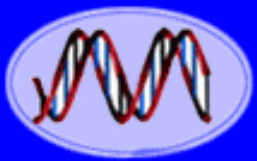

DNA
Genetic Code of Life



Entire Genetic Code
of a Bacteria

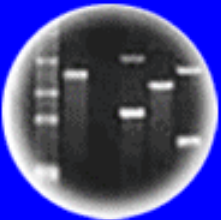

DNA Fingerprinting



Cloning: Ethical Issues
and Future Consequences



Plants of Tomorrow

Fraenkel-Conrat and Bea Singer Used Hybrid Viruses to Demonstrate That RNA Can Be the Genetic Material in 1957

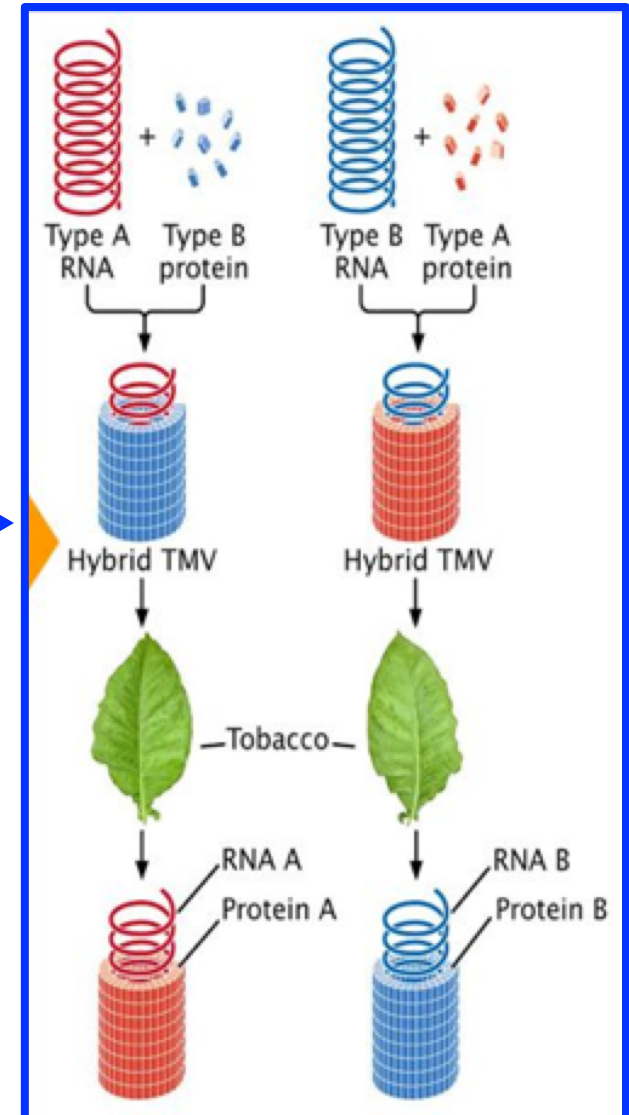
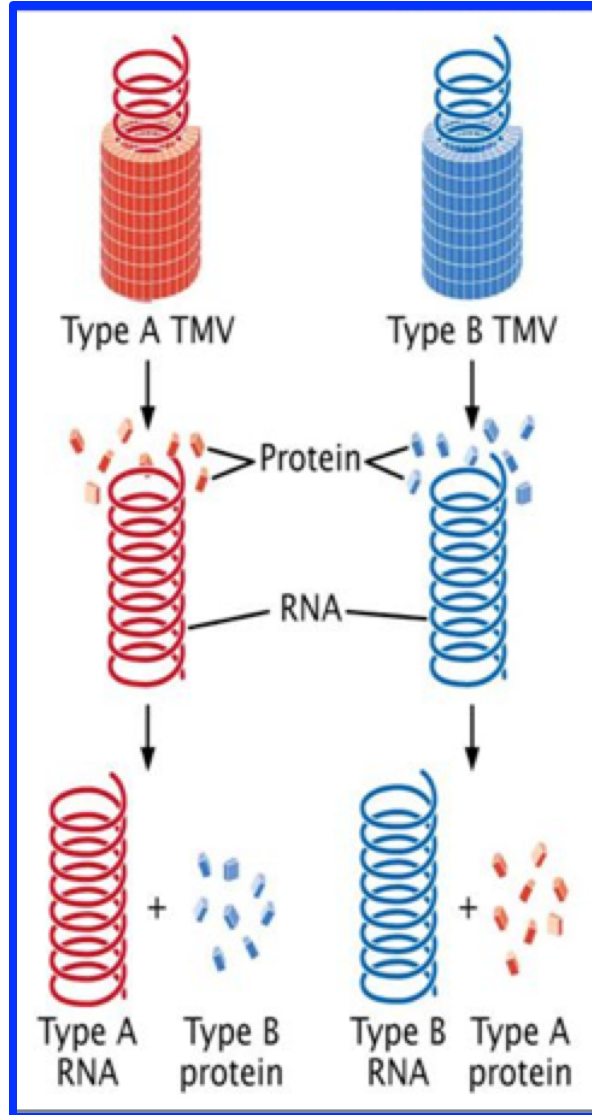

What is A Gene?

5' **Begin**

Sequence or Order of Nucleotides Coding DNA Strand (Coding Strand)

```
TGAAATCCAAAAAATAGGA
GTTTGGTGTGGGTTTAGG
TAGGAATATTTGGGTCTTT
TTTAGGTTTCGGGTTGGGT
ATTTGAGTGTGACATTTGA
AATTCGGTGTTCATCTTCG
TGGGTGTGCCAGTGGCGTGAG
TGTTCCCCGGTTTCGTCACT
TACGGTTTAGGGTTTACCAAG
TTAGGGTTTAGGGTTTGAGAT
GGCGGCCATTTCTCATGTTG
AAACAAGCCTGAAATCAAA
TGGGTGTGCCGGTGGCGTGAG
CGTTCCCCGGTTCGTCACT
ATCAAGTACCCATGTTGGGA
TGAACGTCAATGAACACGAAA
AAAAAATAGGAATCGACCC
AGAAAGGGGAGGGTGGCCATT
ACTATCACGTACACAAAC
ATTTTTTTCGTGGGTGCC
ATAATAGATTTTTCCCTTGT
CCTTTCCATGTTCAAGTACC
TTTCTCATGTTTGAAGTCAR
CCTGAAATCCAAAAAATAG
CAGTGGCGTGAGACATTGGAG
GATACGTCACTAACACGTAA
CATGTTTGGGATTTTTTCCG
AGRACCCAAAAAATAGTCT
GAATCGACCCTTTCCATGT
GGGCAGCCATTTCTCTTGT
AAACAAGCCTGATATCTA
GTGAGTGTGCCAGTGGCGTGA
TCGTTCCCCGGTTCCTTCAAC
GTTCAAGTACCCATGTTGGG
TTGGACGTCAAGAAACCAA
CAAAAAATAGGAATCGACC
AGAAATGGAGGGCGGCCAT
CTGACACGTAAAAACAAGCT
TTTTTTCGTGGGTGTGCCA
AAATAGTCCCGTTCCCCGTT
TTTTCCATGTTCAATTACCA
TCTCATATTTGGACGTCAAG
```

3' **End**

The β -Globin Gene



Blood Protein Carries Oxygen to All Genes From Lungs \Rightarrow Energy

A Gene is a Unique Sequence of Nucleotides Specifying a Function

DNA Sequence = Biology!
What If Sequence Changed?

SEQUENCE \rightarrow FUNCTION

Relative to Coding or Sense Strand of Gene

Genes and Genomes Can Be Sequenced!

Water Gilbert



Fred Sanger

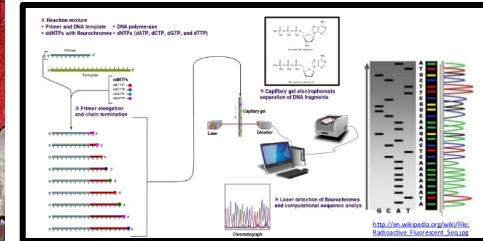
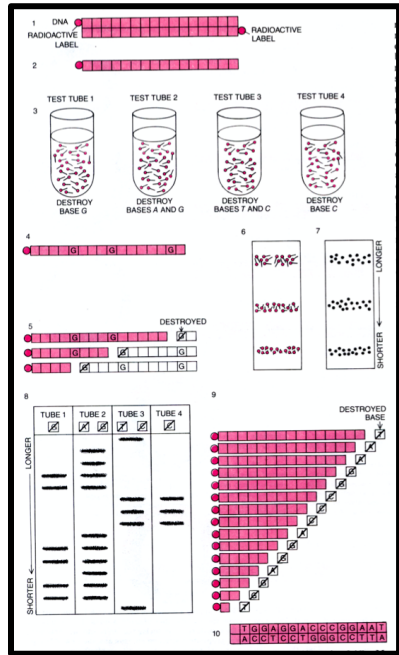

DNA sequencing with chain-terminating inhibitors

(DNA polymerase/nucleotide sequences/bacteriophage φX174)

F. SANGER, S. NICKLEN, AND A. R. COULSON

PNAS December, 1977

A new method for sequencing DNA

(DNA chemistry/dimethyl sulfate cleavage/hydrazine/piperidine)

ALLAN M. MAXAM AND WALTER GILBERT

PNAS February, 1977

The Nobel Prize in Chemistry 1980



Paul Berg
Prize share: 1/2



Walter Gilbert
Prize share: 1/4



Frederick Sanger
Prize share: 1/4

- One half awarded to Paul Berg "for his fundamental studies of the biochemistry of nucleic acids, with particular regard to recombinant-DNA."
- The other half jointly to Walter Gilbert and Frederick Sanger "for their contributions concerning the determination of base sequences in nucleic acids."



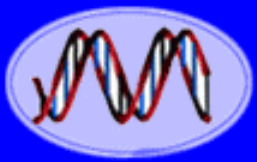

DNA
Genetic Code of Life



Entire Genetic Code
of a Bacteria

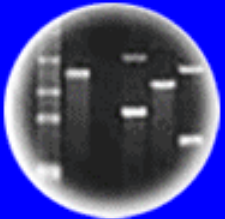

DNA Fingerprinting



Cloning: Ethical Issues
and Future Consequences



Plants of Tomorrow

Genes & Genomes Differ Because the Sequence of DNA Differs

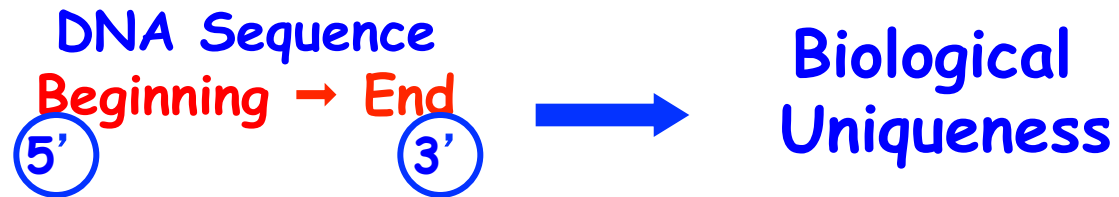

If You Know the DNA Sequence, You
Can Engineer Anything! Even Make New
Genes & Genome!

**Creation of a Bacterial Cell Controlled
by a Chemically Synthesized Genome**

There Are Four Different Nucleotides in DNA

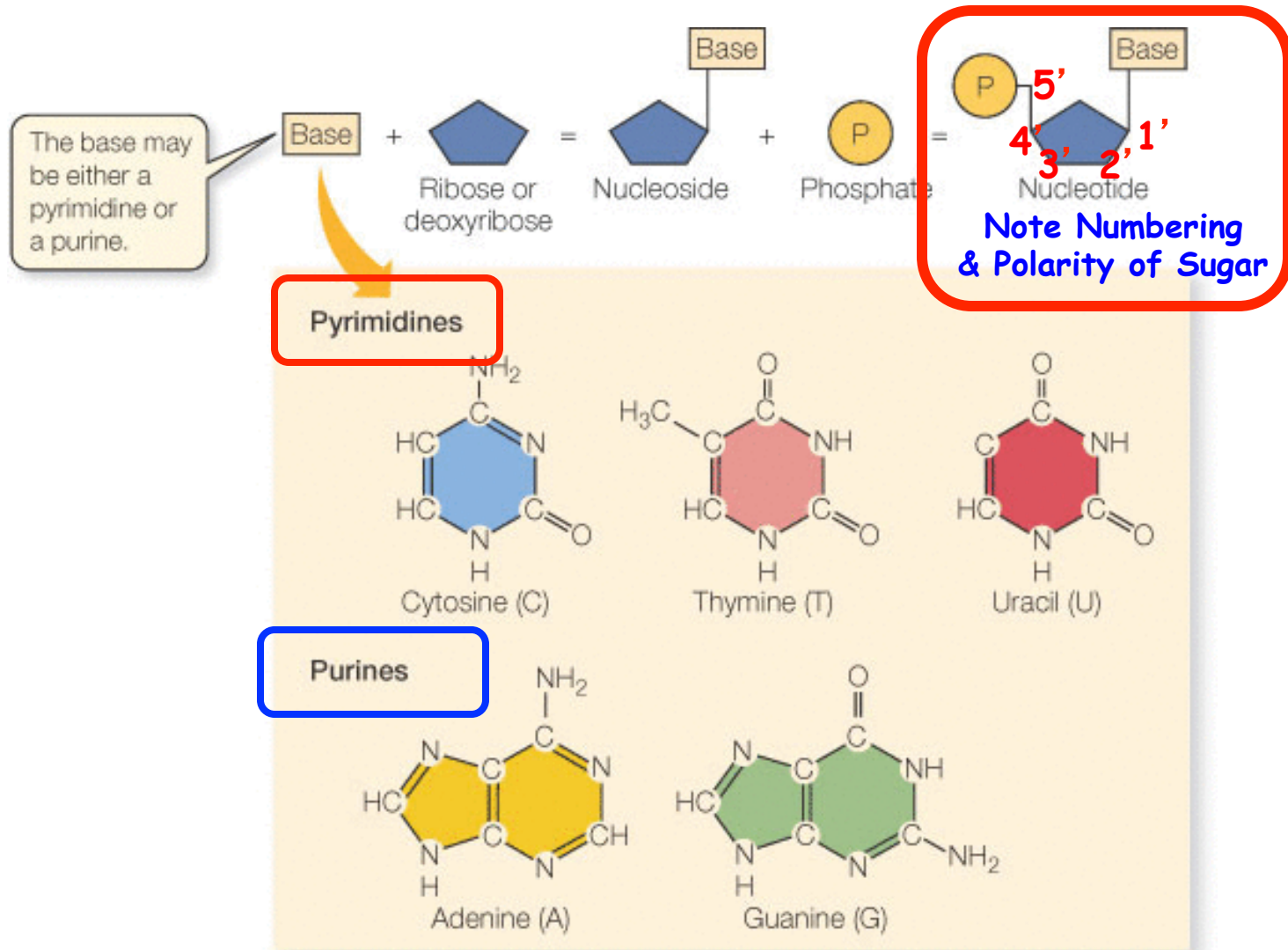

Note Chemical Differences in Bases -- Chemistry Leads to Biology!!

Nucleotides Have Polarity

Based on What is Bonded to the Five-Carbon Sugar
Phosphate on 5' Carbon and **OH** on 3' Carbon

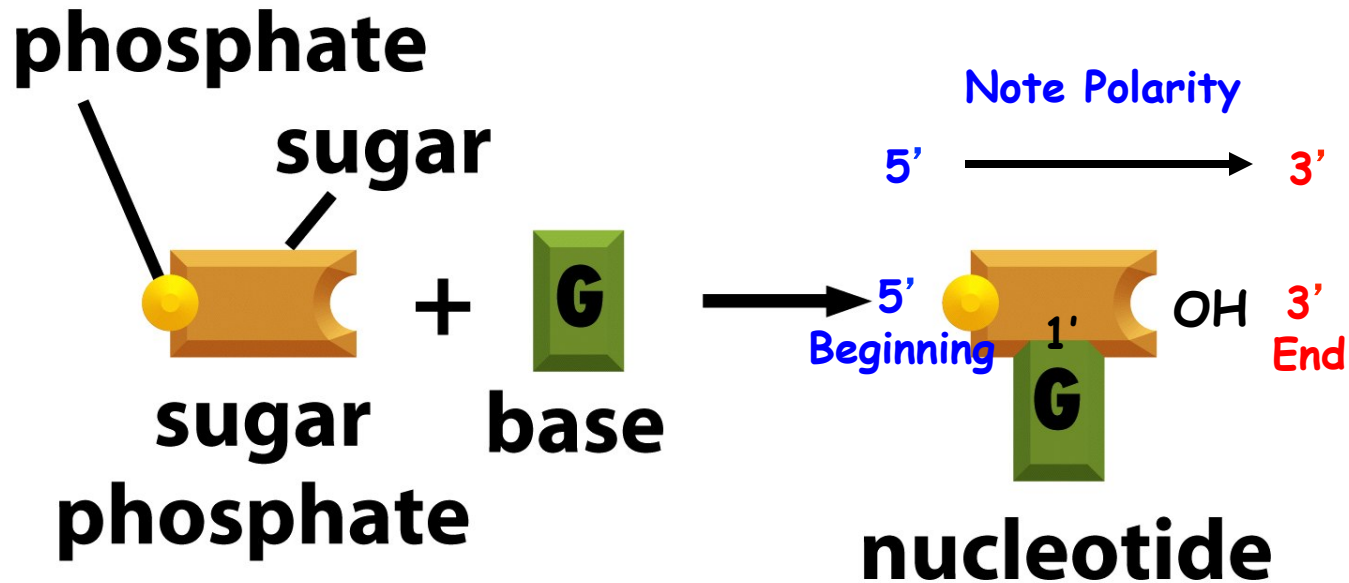

The Sugar is the HUB

DNA Sequence Defined By Nucleotide Order

DNA Sequence = Functional Uniqueness = Biology

TAUTOMERS CHANGE BASE PAIRING RULES

Normal Forms - Keto & Amino

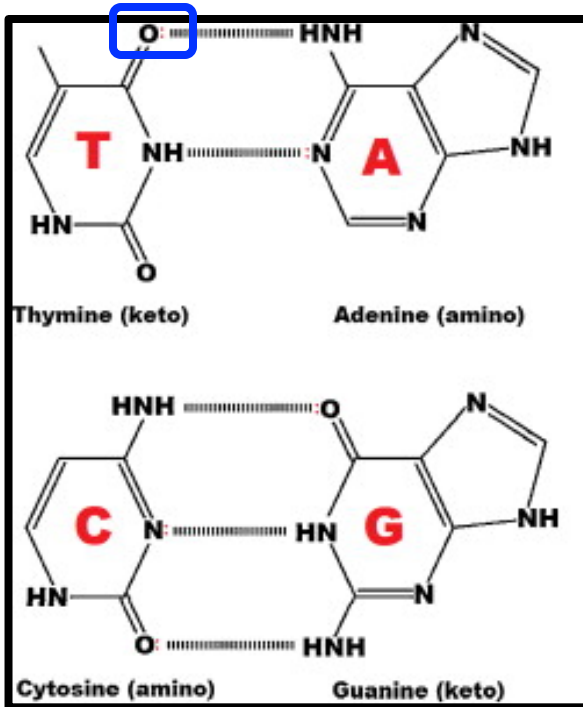

"Mutant" Forms - Enol & Imino

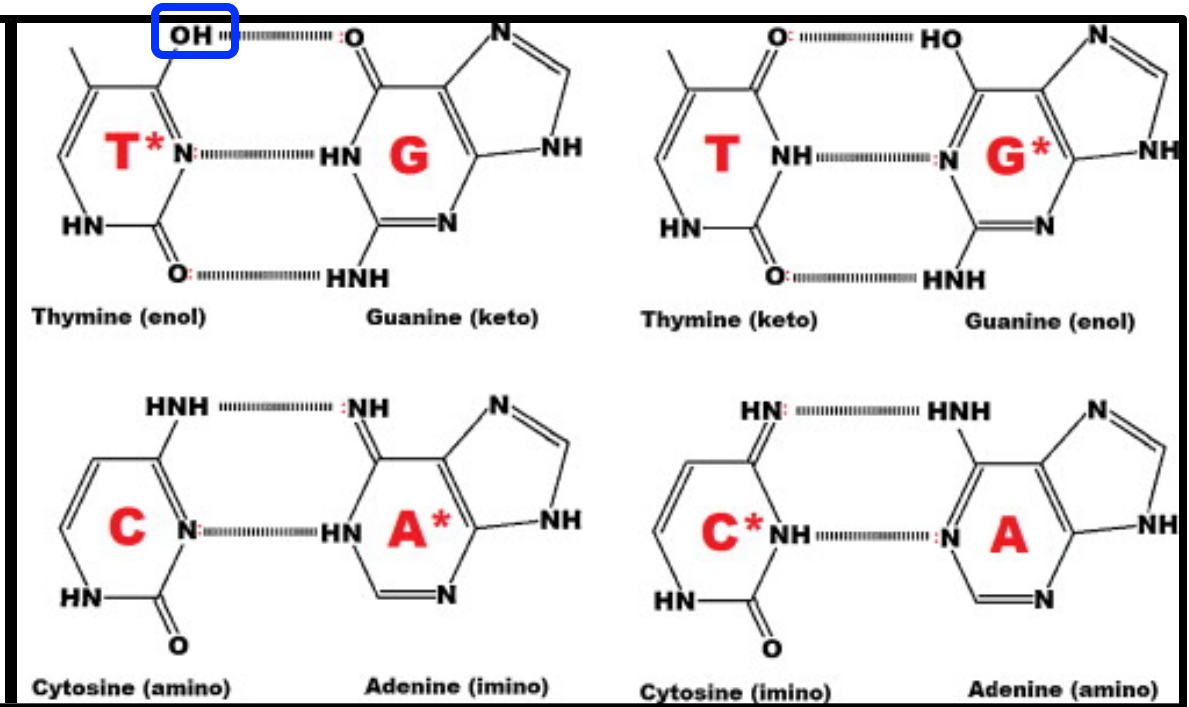

And Lead To Mistakes in DNA
Replication & Mutations ➤ Genetic
Diversity
Chemistry Leads to Biology!!



Nucleotides Are Joined By 5' to 3' Phosphodiester Bonds

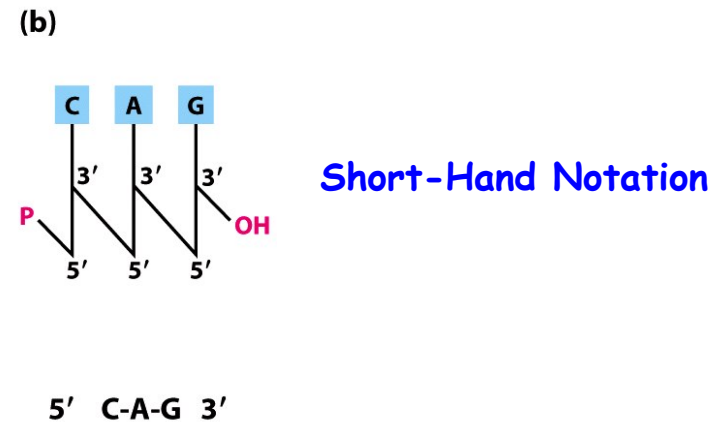
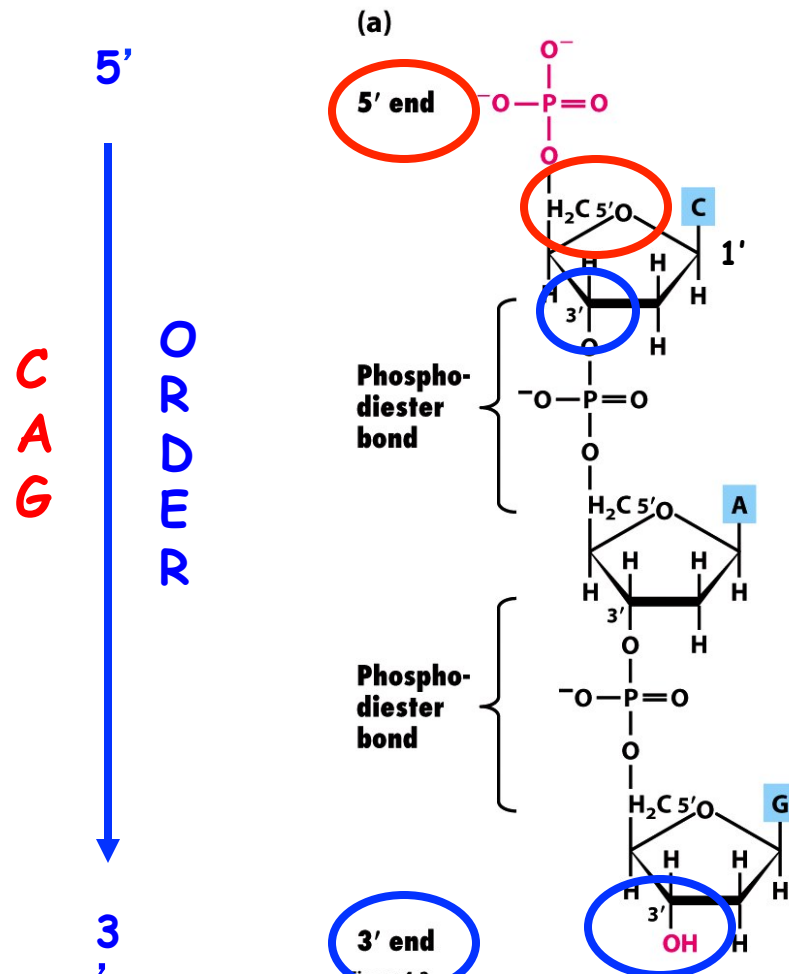

1. The Order is Specified by the Nucleotides That Join 5' to 3'
2. This is the Basis For All of Biology
3. Order is Maintained During DNA Replication
4. Basis of All Genetic Engineering

Figure 4-2
Molecular Cell Biology, Sixth Edition
© 2003 W. H. Freeman and Company

Polarity Defined By

Sugars & Order Specified By Bases

Clues to the Double Helix-Chargaff's Rules

STOPPED

Purines = Pyrimidines

TABLE 6.1 Chargaff's Data on Nucleotide Base Composition in the DNA of Various Organisms

Organism	Percentage of Base in DNA				Ratios	
	A	T	G	C	A:T	G:C
<i>Staphylococcus afermentans</i>	12.8	12.9	36.9	37.5	0.99	0.99
<i>Escherichia coli</i>	26.0	23.9	24.9	25.2	1.09	0.99
Yeast	31.3	32.9	18.7	17.1	0.95	1.09
<i>Caenorhabditis elegans</i> *	31.2	29.1	19.3	20.5	1.07	0.96
<i>Arabidopsis thaliana</i> *	29.1	29.7	20.5	20.7	0.98	0.99
<i>Drosophila melanogaster</i>	27.3	27.6	22.5	22.5	0.99	1.00
Honeybee	34.4	33.0	16.2	16.4	1.04	0.99
<i>Mus musculus</i> (mouse)	29.2	29.4	21.7	19.7	0.99	1.10
Human (liver)	30.7	31.2	19.3	18.8	0.98	1.03

*Data for *C. elegans* and *A. thaliana* are based on those for close relative organisms.

Note that even though the level of any one nucleotide is different in different organisms, the amount of A always approximately equals the amount of T, and the level of G is always similar to that of C. Moreover, as you can calculate for yourself, the total amount of purines (A plus G) nearly always equals the total amount of pyrimidines (C plus T).

What Would You Predict For a Single-Stranded DNA?

THE COMPOSITION OF THE DESOXYRIBOSE NUCLEIC
ACIDS OF THYMUS AND SPLEEN*

BY ERWIN CHARGAFF, ERNST VISCHER,† RUTH DONIGER, CHARLOTTE
GREEN, AND FERNANDA MISANI

J. Biological Chemistry,
July, 1948

Erwin Chargaff, 96, Pioneer In DNA Chemical Research

By NICHOLAS WADE
Published: June 30, 2002

Erwin Chargaff, whose research into the chemical composition of DNA helped lay the groundwork for James Watson and Francis Crick's discovery of its double-helix structure -- the pivotal finding of 20th-century biology -- died on June 20 in a New York hospital. He was 96.

As a biochemist at Columbia University in the 1940's, Dr. Chargaff discovered regularities among the four chemical units of DNA known as bases, pointing directly to its role as the hereditary material of living organisms. But he was unable to interpret the meaning of his finding, a failure that allowed Dr. Watson and Dr. Crick to do so when they ascertained the structure of DNA.

Dr. Chargaff's data helped both in the two young scientists' discovery and even more in its acceptance by other scientists. "The base composition was an essential clue for finding the structure of DNA, there's no doubt about that," Dr. Watson said in an interview. "We could have come up with the answer, but no one would have believed it."

Dr. Chargaff later became a forceful if lonely critic of molecular biology, accusing its practitioners of "practicing biology without a license" when they learned to move genes from one organism to another.

A man of wide culture and learning, he did not fit easily into the sharply focused world of scientific specialists. Ever the European, he found much in American life to criticize, despite his long and productive tenure at Columbia. He cherished the outsider's role, modeling his sardonic view of the world on the writings of Karl Kraus, the Viennese satirist.

"I have not fitted well," Dr. Chargaff wrote in 1975, "into the country and the society in which I had to live; into the language in which I had to converse; yes, even into the century in which I was born."

Erwin Chargaff was born on Aug. 11, 1905, in Czernowitz, then a provincial capital of the Austrian monarchy. His father, Hermann, was a banker who later lost his business. Of his mother, Rosa Silberstein, he wrote that she died, "only God knows where and when, having been deported into nothingness from Vienna in 1943." He is survived by his only son, Thomas.

As a young man, Dr. Chargaff studied chemistry at the University of Vienna. He worked at the University of Berlin and then at the Pasteur Institute in Paris before arriving at Columbia University in 1935. After reading the 1944 report by Oswald Avery that identified DNA as the hereditary material, Dr. Chargaff switched his laboratory to the study of DNA and the four bases, or chemical groups, of which it is composed -- adenine, cytosine, guanine and thymine.

He soon noticed a striking regularity about the base composition of DNA: from whatever plant or animal he derived DNA, the amounts of adenine and thymine were almost the same, and so were the amounts of cytosine and guanine.

Dr. Chargaff published the result but made little progress in understanding the reason for the regularity, which is that adenine on one of the DNA molecule's two strands is always paired with thymine on the other, as is cytosine with guanine. But in a fateful and testy lunch in May 1952, he discussed his results with Dr. Watson and Mr. Crick (who did not yet have his doctorate).

"They impressed me by their extreme ignorance," he later told Horace Judson, the historian of the discovery of DNA. "They told me they wanted to construct a helix, a polynucleotide to rival Pauling's alpha helix. They talked so much about 'pitch' that I remember I wrote down afterwards, 'Two pitchmen in search of a helix.'"

He later wrote that "I believe that the double-stranded model of DNA came about as a consequence of our conversation." Mr. Judson, however, in an appendix to a new edition of his book "The Eighth Day of Creation" (Cold Spring Harbor Press, 1996), concluded that Dr. Chargaff's claim was something of a stretch, since Dr. Watson and Dr. Crick had not at that time hit on the concept of base pairing, nor had Dr. Chargaff alluded to it in his publications.

Though Dr. Chargaff tended toward the sardonic, it was hard for observers to understand the depth of his bitterness in his attitude to his fellow scientists. The reason, besides his disappointment at having missed discovering the structure of DNA, was that he was pushed to the sidelines by Dr. Crick in the worldwide effort to interpret the structure.

"By 1958," Mr. Judson writes, "Dr. Chargaff was denouncing molecular biology and its practitioners for arrogance, ignorance, reductionism and self-serving sensationalism."

"The technology of genetic engineering poses a greater threat to the world than the advent of nuclear technology"

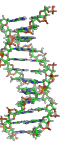
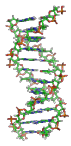

DNA is a Double Helix of Two Complementary Chains of DNA Wound Around Each Other

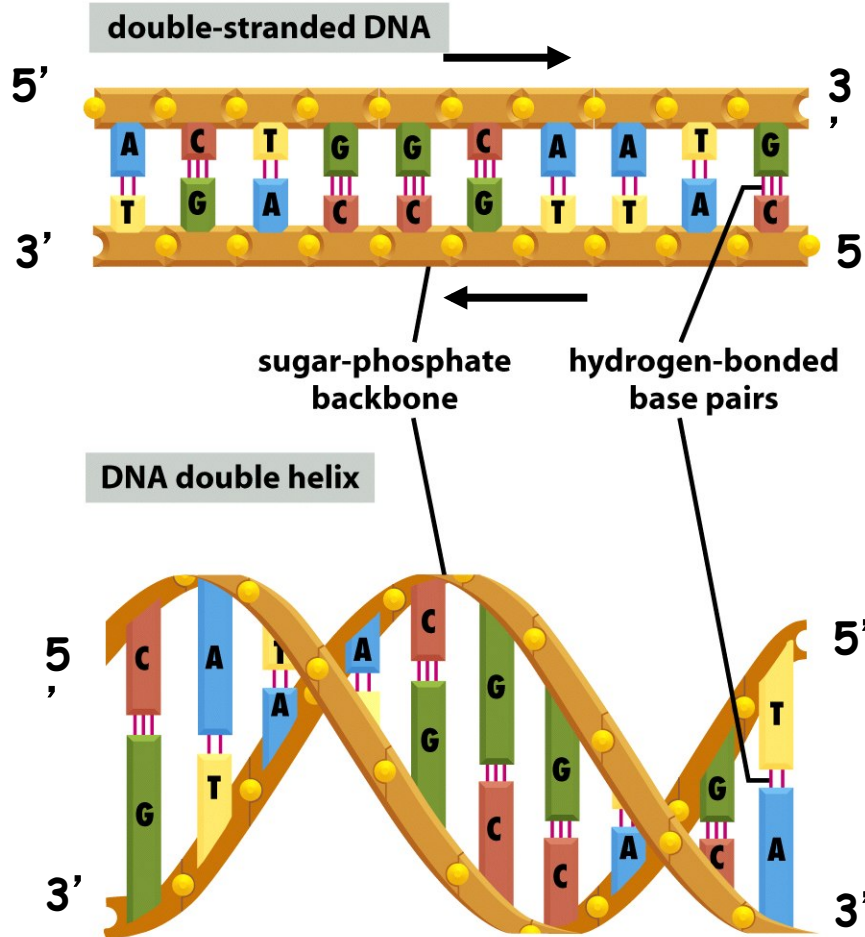

1. Complementary Strands
2. $A=T$ and $G=C$ (Four Bases)
3. Sequence of Strands Differ
4. Bases to Interior
5. Phosphate-Sugar Backbone on Exterior
6. DNA Strands in Opposite Direction (Only Way Helix Fits)
7. Sequence of One Chain Automatically Specifies Sequence of Complementary Chain (Basis of Replication!)
8. No Constraint on Sequence
($4^n = n$ # sequences)
9. DNA has dimensions (Know # bp
Know Length: 20\AA diameter, $3.4\text{\AA}/\text{bp}$, $10\text{bp}/\text{turn}$)
10. Sequence = Biology

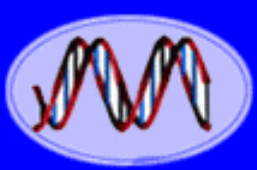

DNA
Genetic Code of Life



Entire Genetic Code
of a Bacteria

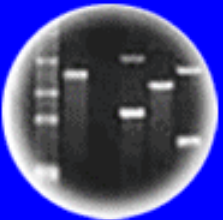

DNA Fingerprinting



Cloning: Ethical Issues
and Future Consequences



Plants of Tomorrow



Reflections on *The Double Helix*

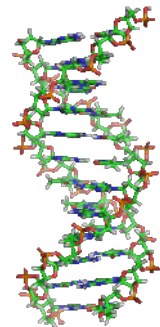
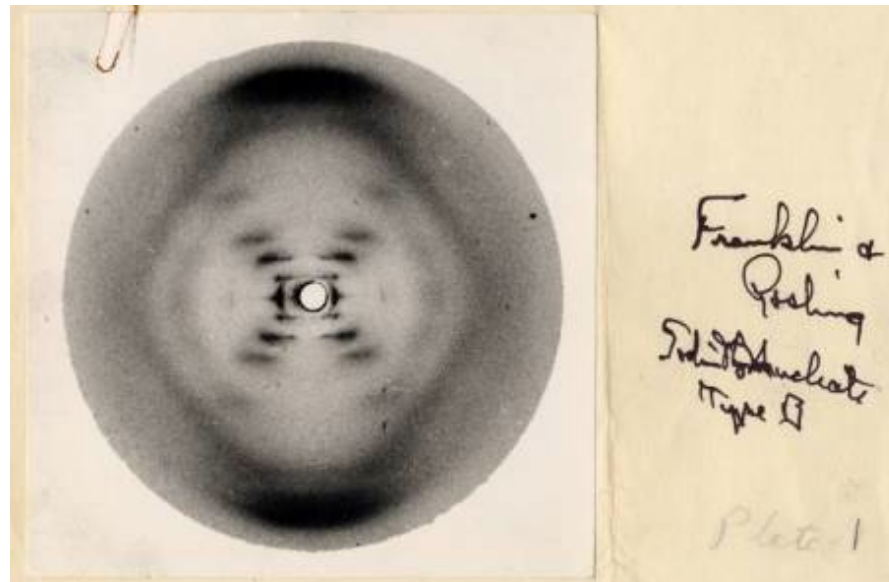
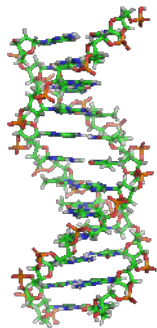





DNA
Genetic Code of Life



Entire Genetic Code
of a Bacteria

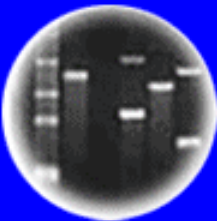

DNA Fingerprinting



Cloning: Ethical Issues
and Future Consequences



Plants of Tomorrow

MOLECULAR STRUCTURE OF NUCLEIC ACIDS

A Structure for Deoxyribose Nucleic Acid

WE wish to suggest a structure for the salt of deoxyribose nucleic acid (D.N.A.). This structure has novel features which are of considerable biological interest.

Nature, April 25, 1953

We are much indebted to Dr. Jerry Donohue for constant advice and criticism, especially on inter-atomic distances. We have also been stimulated by a knowledge of the general nature of the unpublished experimental results and ideas of Dr. M. H. F. Wilkins, Dr. R. E. Franklin and their co-workers at

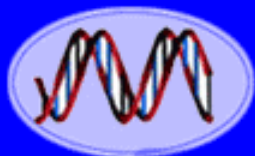

DNA
Genetic Code of Life



Entire Genetic Code
of a Bacteria



DNA Fingerprinting



Cloning: Ethical Issues
and Future Consequences



Plants of Tomorrow

Molecular Structure of Deoxypentose Nucleic Acids

M. H. F. WILKINS
Medical Research Council Biophysics
Research Unit,

A. R. STOKES
H. R. WILSON
Wheatstone Physics Laboratory,
King's College, London. *Nature*, April 25, 1953
April 2.

Molecular Configuration in Sodium Thymonucleate

ROSALIND E. FRANKLIN*
R. G. GOSLING
Wheatstone Physics Laboratory,
King's College, London. *Nature*, April 25, 1953
April 2.

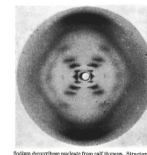

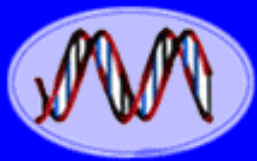

DNA
Genetic Code of Life



Entire Genetic Code
of a Bacteria

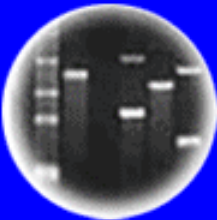

DNA Fingerprinting



Cloning: Ethical Issues
and Future Consequences



Plants of Tomorrow

GENETICAL IMPLICATIONS OF THE STRUCTURE OF DEOXYRIBONUCLEIC ACID

By J. D. WATSON and F. H. C. CRICK

Medical Research Council Unit for the Study of the
Molecular Structure of Biological Systems, Cavendish
Laboratory, Cambridge Nature, May 30, 1953

No. 4361 May 30, 1953 NAT

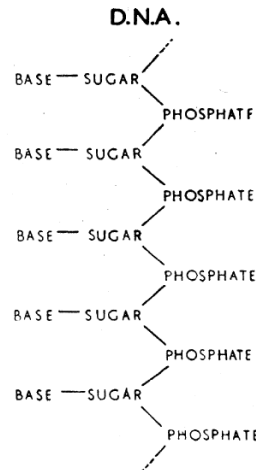

Fig. 1. Chemical formula of a single chain of deoxyribonucleic acid



Fig. 2. This figure is purely diagrammatic. The two ribbons symbolize the two phosphate-sugar chains, and the horizontal rods the pairs of bases holding the chains together. The vertical line marks the fibre axis

Our model suggests possible explanations for a number of other phenomena. For example, spontaneous mutation may be due to a base occasionally occurring in one of its less likely tautomeric forms. Again, the pairing between homologous chromosomes at meiosis may depend on pairing between specific bases. We shall discuss these ideas in detail elsewhere.

For the moment, the general scheme we have proposed for the reproduction of deoxyribonucleic acid must be regarded as speculative. Even if it is correct, it is clear from what we have said that much remains to be discovered before the picture of genetic duplication can be described in detail. What are the polynucleotide precursors? What makes the pair of chains unwind and separate? What is the precise role of the protein? Is the chromosome one long pair of deoxyribonucleic acid chains, or does it consist of patches of the acid joined together by protein?

Despite these uncertainties we feel that our proposed structure for deoxyribonucleic acid may help to solve one of the fundamental biological problems—the molecular basis of the template needed for genetic replication. The hypothesis we are suggesting is that the template is the pattern of bases formed by one chain of the deoxyribonucleic acid and that the gene contains a complementary pair of such templates.

A Chromosome Contains One (or Two!!) Continuous DNA Molecule(s)

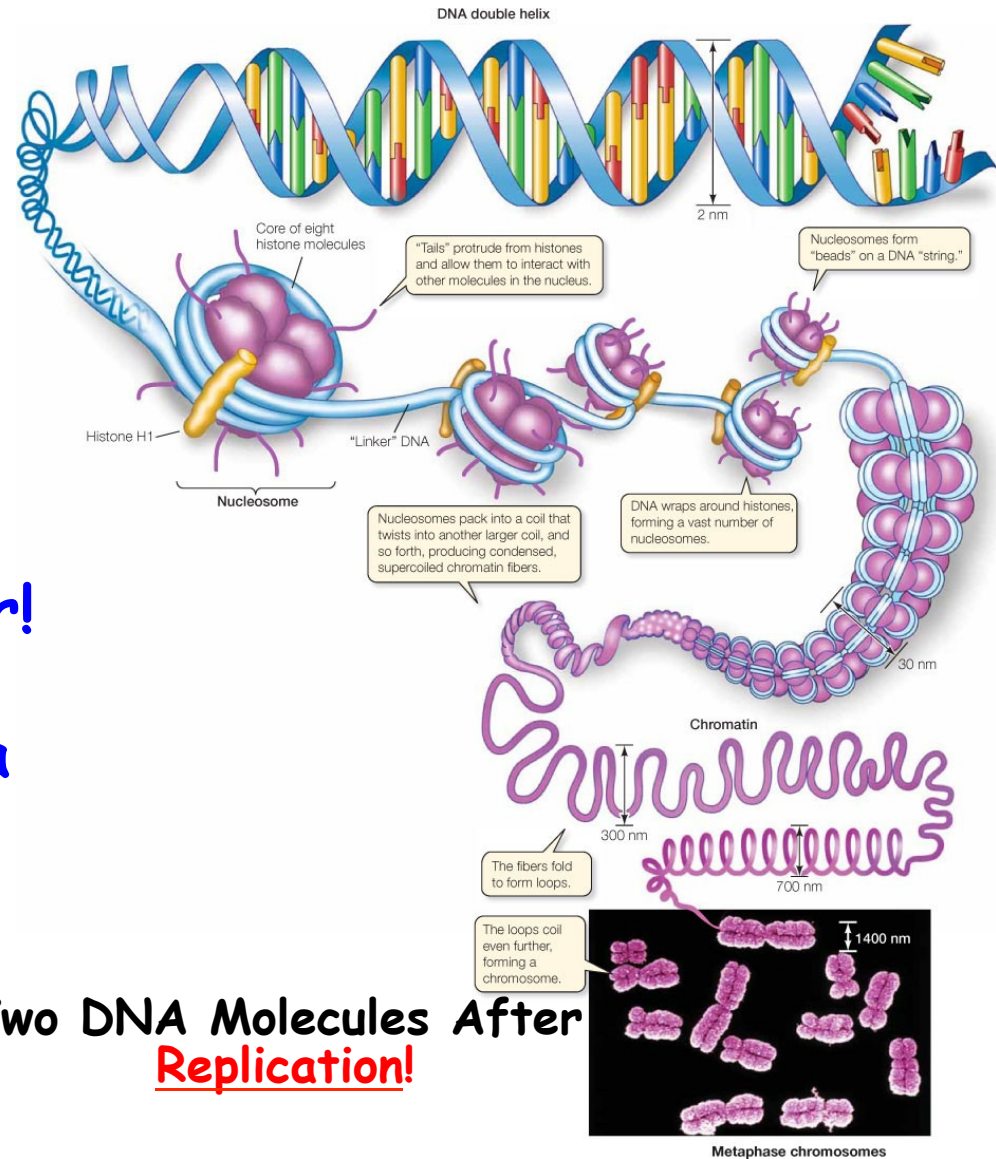

DNA in Human & Eukaryotic Chromosomes is Linear!

DNA in Most Bacteria is Circular!

Two DNA Molecules After Replication!

A Chromosome Contains Many Genes Operating Independently

What is the Evidence?

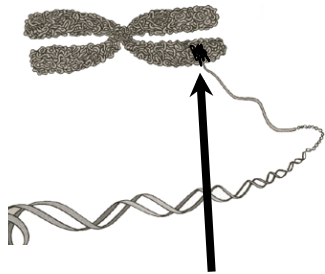

**Position of Genes
1, 2, & 3 in
chromosome**

Discrete Units!

Notice- Each gene, mRNA, & protein has a unique order/sequence of monomeric units

Central Dogma

**∴ Genes → Functions in Cells
via Proteins**

**Cells duplicate & stay the same
→ DNA replication**

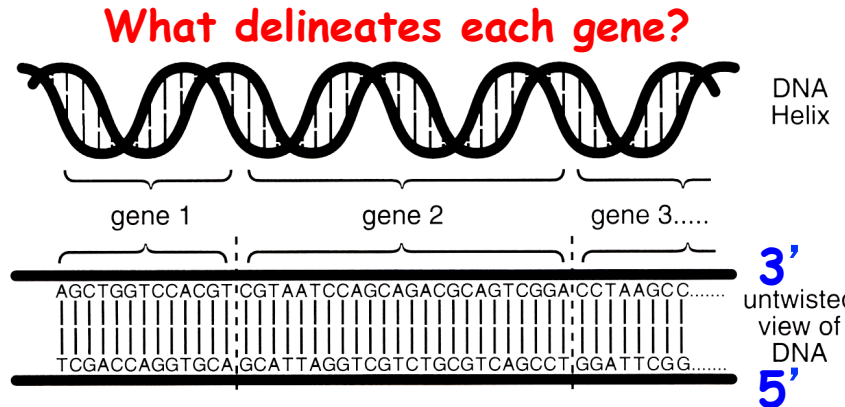

Notice sequence of each gene

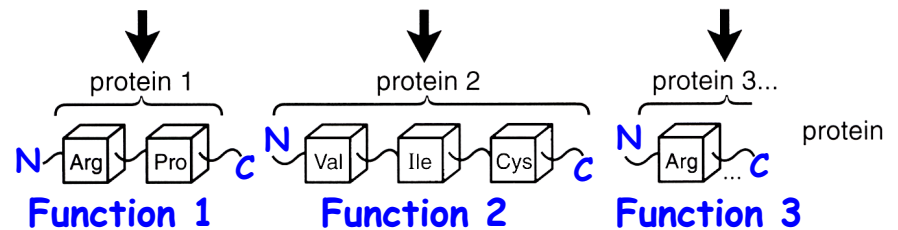
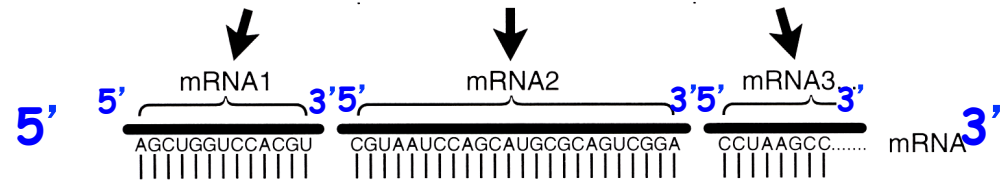

Note sequence of each protein

VERY IMPORTANT CONCEPT!

COLINEARITY BETWEEN GENE SEQUENCE AND PROTEIN SEQUENCE

A Chromosome Contains Many Genes That Reside at Specific Positions and Have Unique Functions

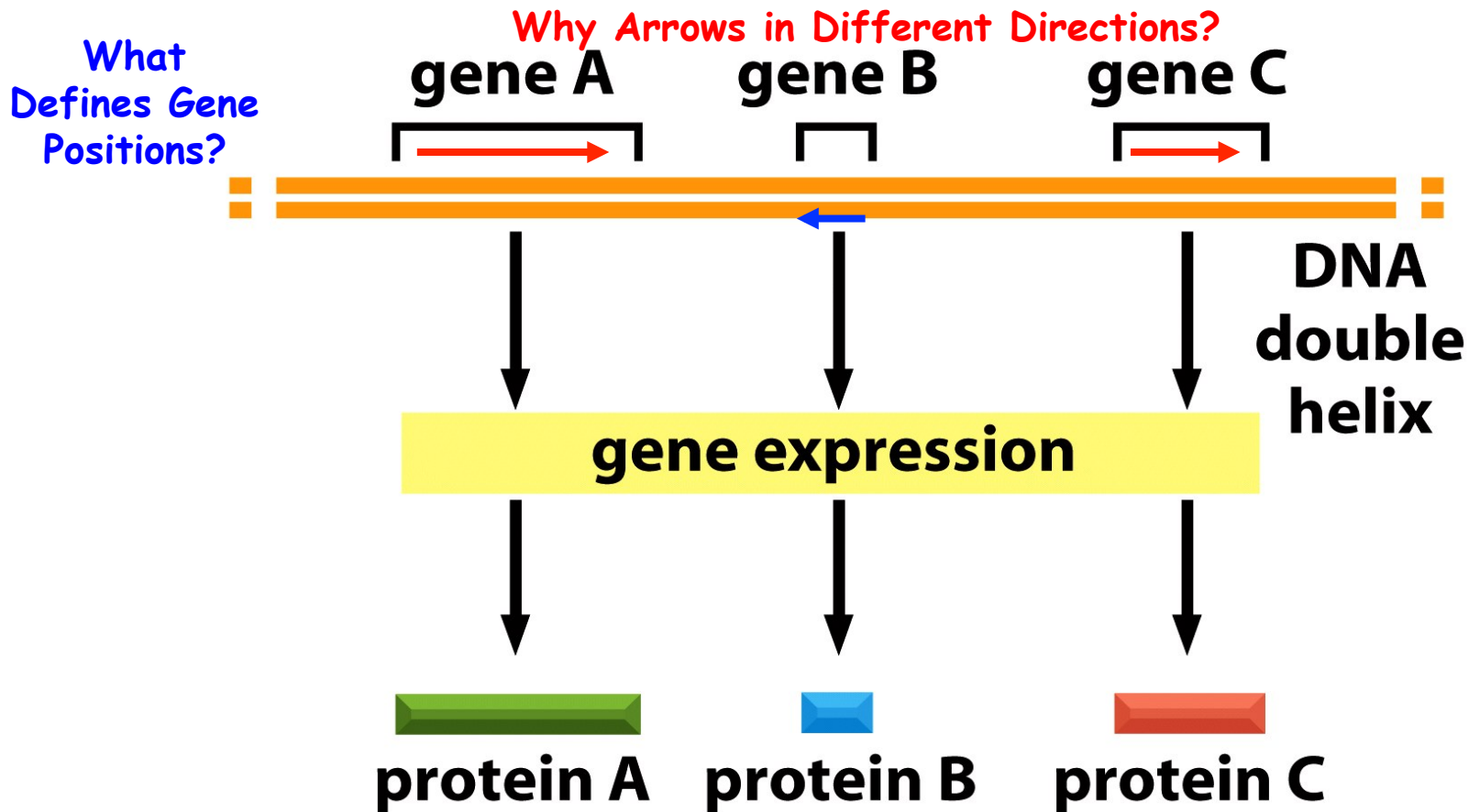

Because DNA Contains Two Strands--Genes Can Be Transcribed From Either Strand--But Only One Per Gene

Genes Reside at Specific Positions or **Loci**

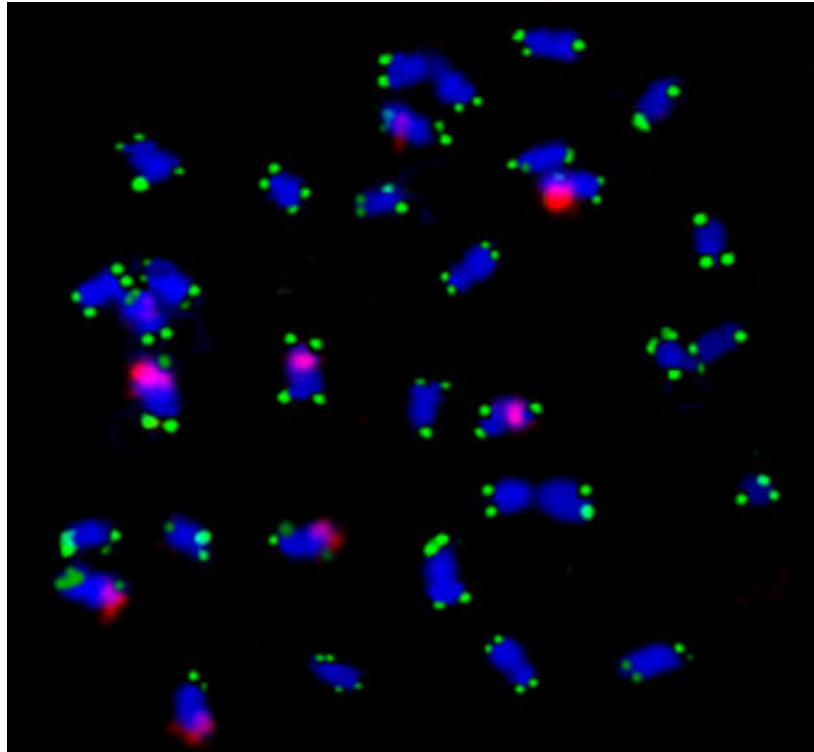

Gene Position = Locus = Unique DNA
Sequence

Genes Reside at Specific Locations That Can Be Mapped

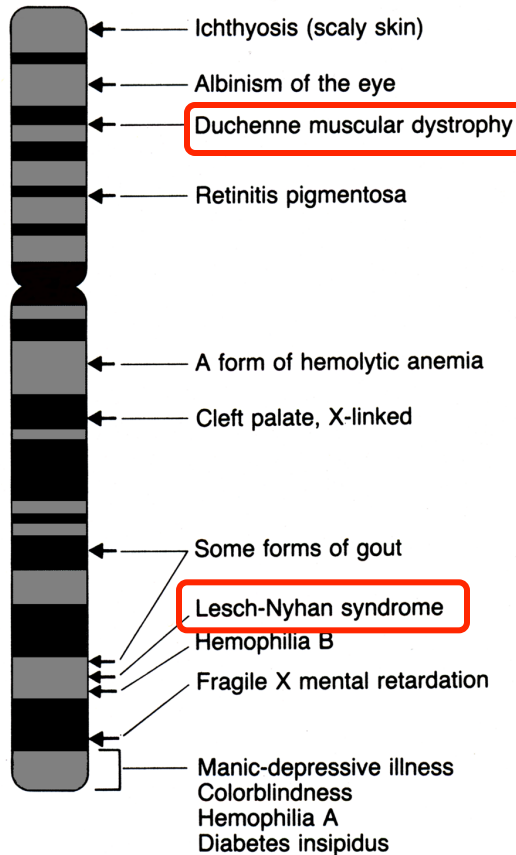

Human X Chromosome

Linear DNA
How Know?

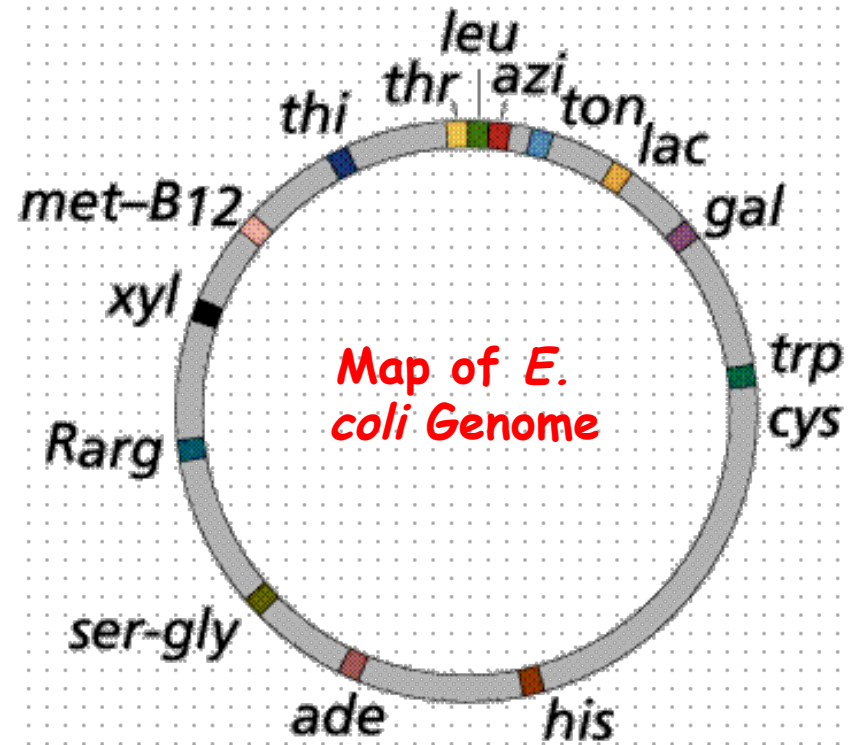

Circular DNA
How Know?

- Note **Marker Bands** - What are these? How are they useful?
- How Determine Gene Positions? Chromosome Number?

Alleles Reside at the Same Position on a Chromosome

Allele Phenotypes Specify Markers For Each Gene Location!

Alleles

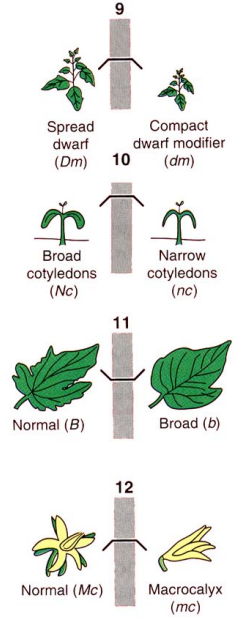
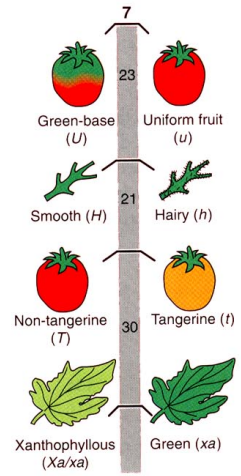
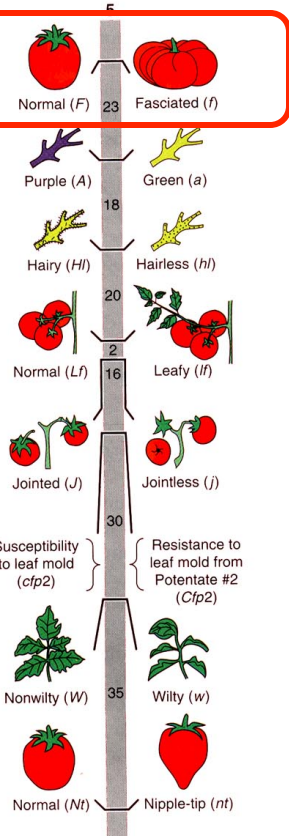

Gene Engineering Can Generate New Forms of Alleles of a Gene and, therefore, Results in More Genetic Diversity

Different Genes

mutations result in genetic diversity!!!

Alleles Are Different Forms of the Same Gene That Arise By Mutation & Can be Made in a Laboratory By Modern Genetic Engineering!

Organization of Genes on Human Chromosome 22

(A) human chromosome 22 in its mitotic conformation, composed of two DNA molecules, each 48×10^6 nucleotide pairs long



250 genes



10% of chromosome arm ~40 genes



Genes Are Defined/
Precise Regions of
DNA

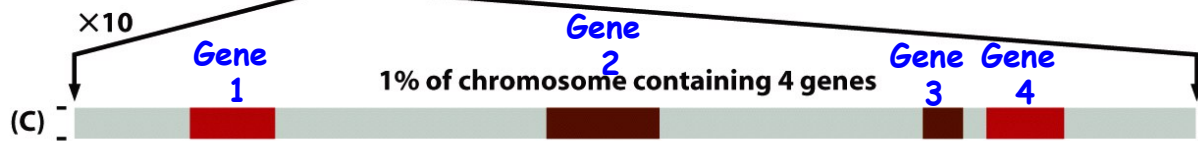

One Large Gene!

Genes Act As Individual Units?

How Know? **GloFish** Experiment! **Genetic Engineering Antibiotic^R**

A Conceptualized Gene

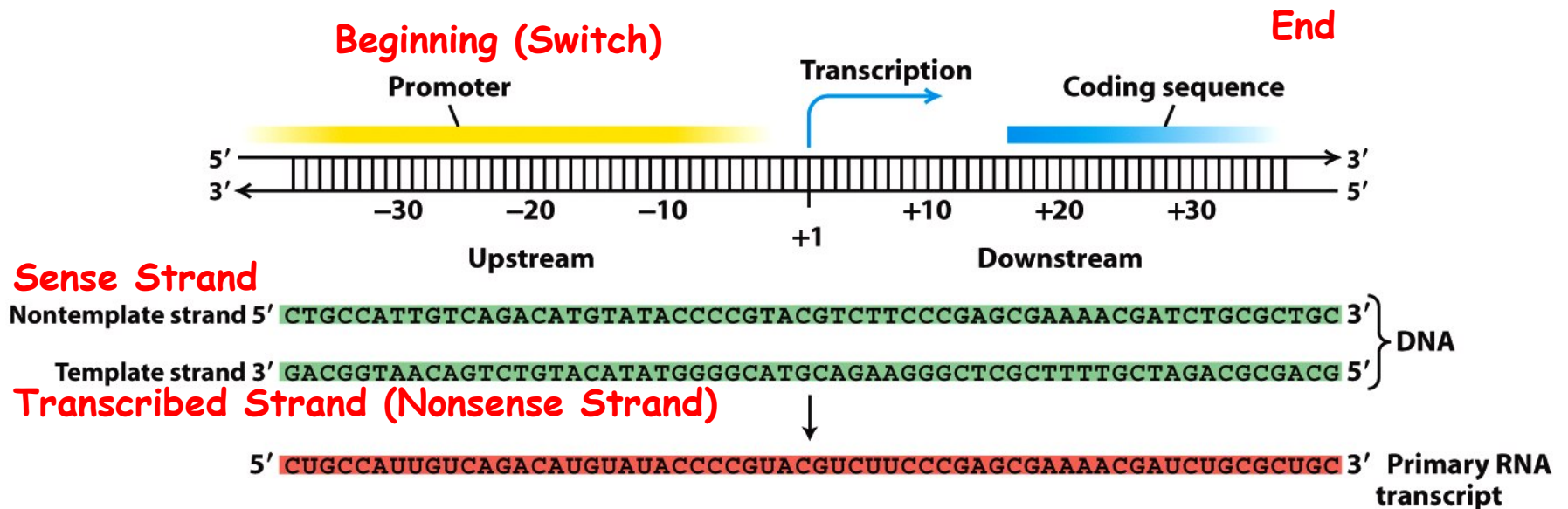
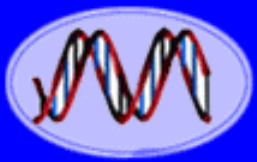

Figure 4-10b
Molecular Cell Biology, Sixth Edition
 © 2008 W. H. Freeman and Company

Major Concept in "Making Proteins in Recombinant Bacteria" Article by Gilbert

A "Simple" Gene Reviewed



DNA
Genetic Code of Life



Entire Genetic Code
of a Bacteria

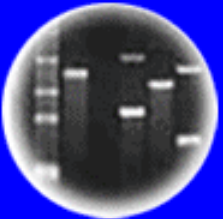

DNA Fingerprinting



Cloning: Ethical Issues
and Future Consequences



Plants of Tomorrow

1. Sense Strand = Genetic Code
2. Sense Strand = 5' → 3' Direction (all DNA sequences specified 5' → 3')
3. Anti Sense Strand = Complement of Sense Strand & is Transcribed Strand
4. mRNA = Same Sequence As Sense Strand & Complementary to AntiSense Strand
5. mRNA = 5' → 3'
6. Switch Turns Gene On - Not Transcribed But Upstream of Coding Region

Genes Function As Independent Units! How Know? Design Experiment to Show!

"Everything" Follows the Double Helix & Its Rules - Anti-parallel Chains & Complementary Base Pairing!

Control Switches Are Unique DNA Sequences & Can Be Cloned

AND used to Re-Engineer Organisms!! Switches Act Independently of Gene!!

**“Control”
Switch**

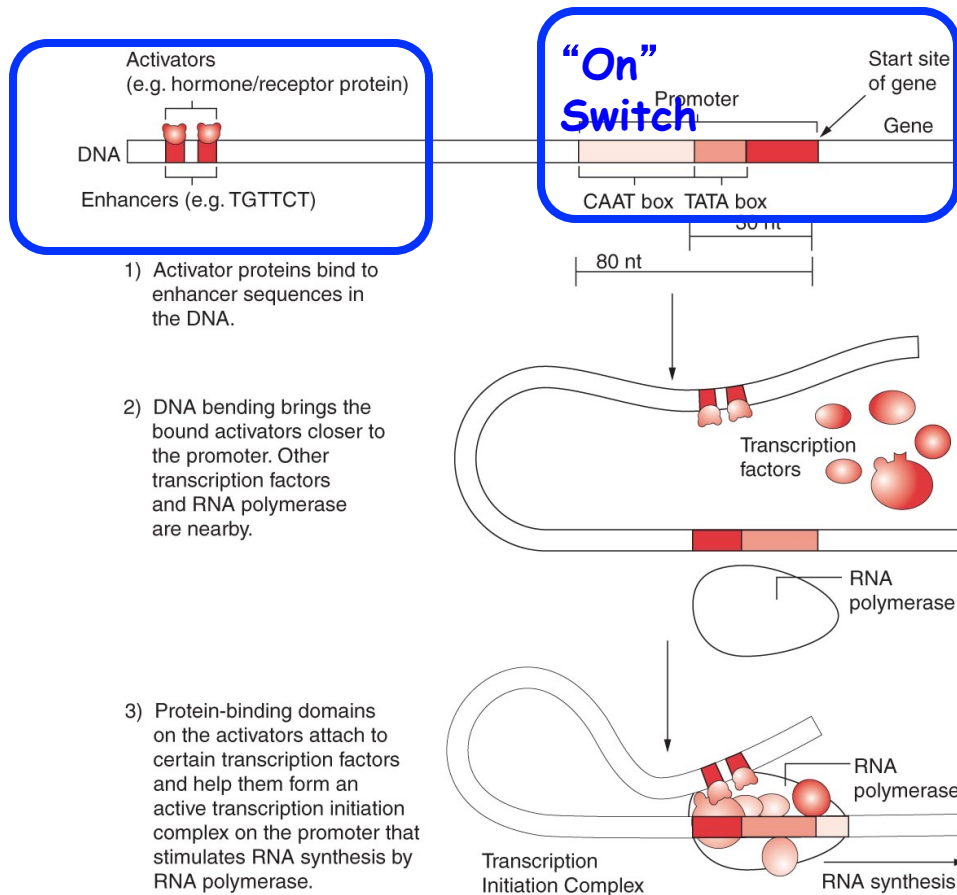

1. Each Switch Has a Unique DNA Sequence
2. Genome Projects Reveal Genes & Logic Controlled by the Switches
3. Sequence = Biology
4. No Hocus Pocus
5. Yo! It's in the DNA!!

Legos!!!

Switches Control Where & When A Gene Is Active → Unique Functions → Unique Cells

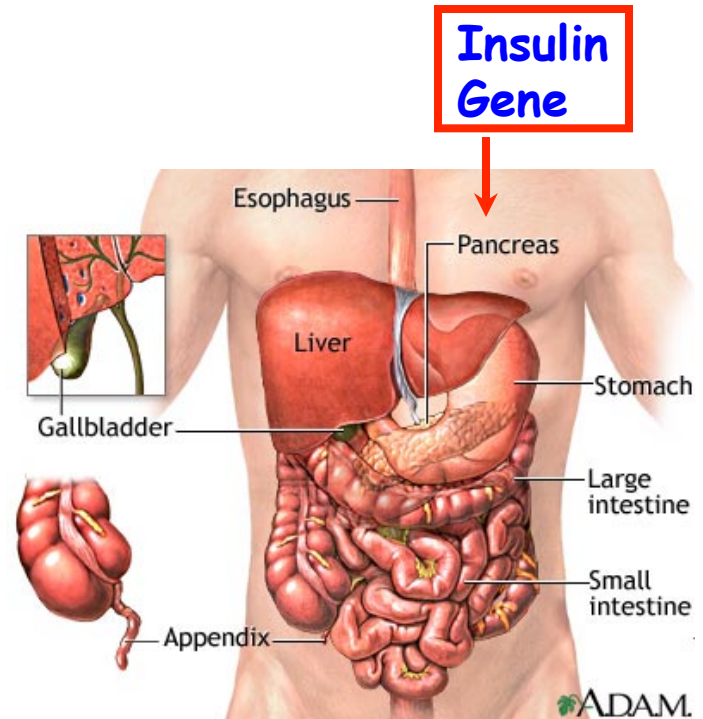
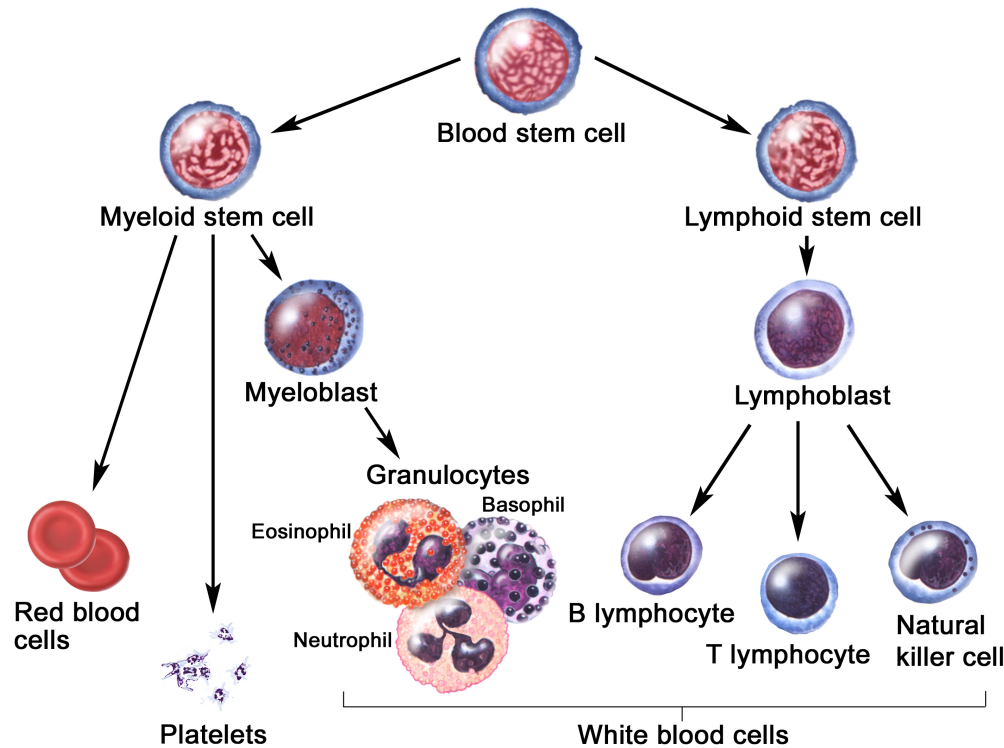



DNA
Genetic Code of Life



Entire Genetic Code
of a Bacteria

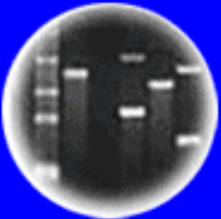

DNA Fingerprinting



Cloning: Ethical Issues
and Future Consequences



Plants of Tomorrow

THE GENE AND SWITCHES ARE UNIQUE DNA SEQUENCES

1. They Can Be Cloned & “Shuffled” & Engineered Creating **New** Genes That Have No Counterparts in Nature. ⇒ **Genetic Engineering**
2. These New Genes Can Be Transcribed in New Cell Types (Switch Change) &/or Organisms &/or Both. (e.g., Human Genes in Bacteria)



Human Genes + Bacterial Switch

3. All Genes are Regulated & Controlled by Switches. Genome Projects Reveal Both the Genes & the Switches & Wiring Together of All Switches in Gene. ⇒ Program of Life From Birth to Death

Yo! It's in the Sequences!!

The Eye Gene Can Be Expressed in Different Parts of the Fly by Engineering the Eye Switch

Eye Gene



Replace the Head Switch With the Leg Switch by Genetic Engineering



Eye Gene
+
Leg Switch

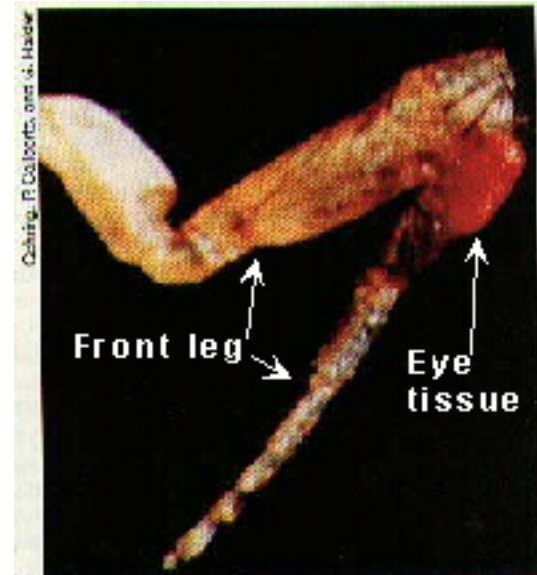

Abnormal activity of the eyeless gene has generated an eye on the leg of a fly.

Eye Regulatory Network

Control Genes Like The Eye Gene Control The Activity of Other Genes!

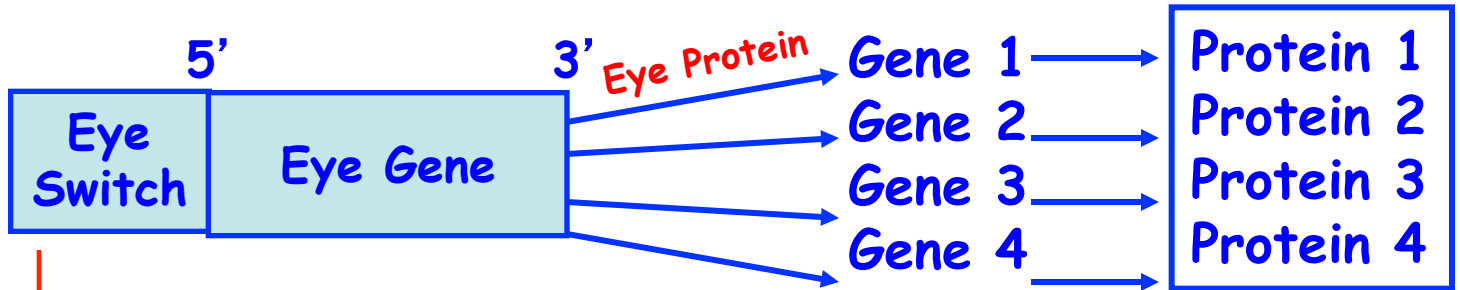

Works in Head!

Eye Protein Binds to Switches to Turn Genes On!

Eye on Head!

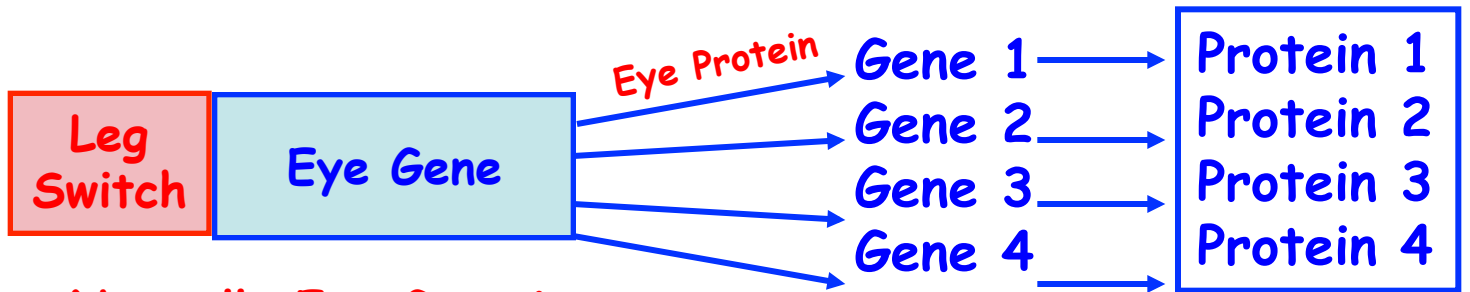

Normally Eye Gene is OFF in Leg. Switch only Works in Leg.

Eye on Leg!

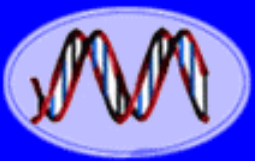

DNA
Genetic Code of Life



Entire Genetic Code
of a Bacteria

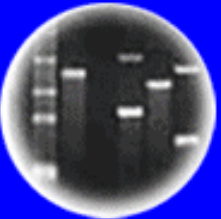

DNA Fingerprinting



Cloning: Ethical Issues
and Future Consequences



Plants of Tomorrow

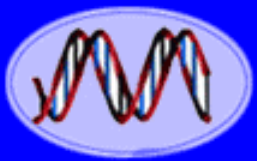

DNA
Genetic Code of Life



Entire Genetic Code
of a Bacteria

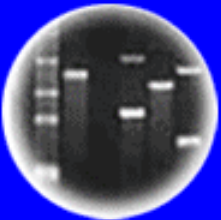

DNA Fingerprinting



Cloning: Ethical Issues
and Future Consequences



Plants of Tomorrow

Ultimate Goal: To Dissect Genetic Regulatory Networks Programming Human Development From Birth to Death!

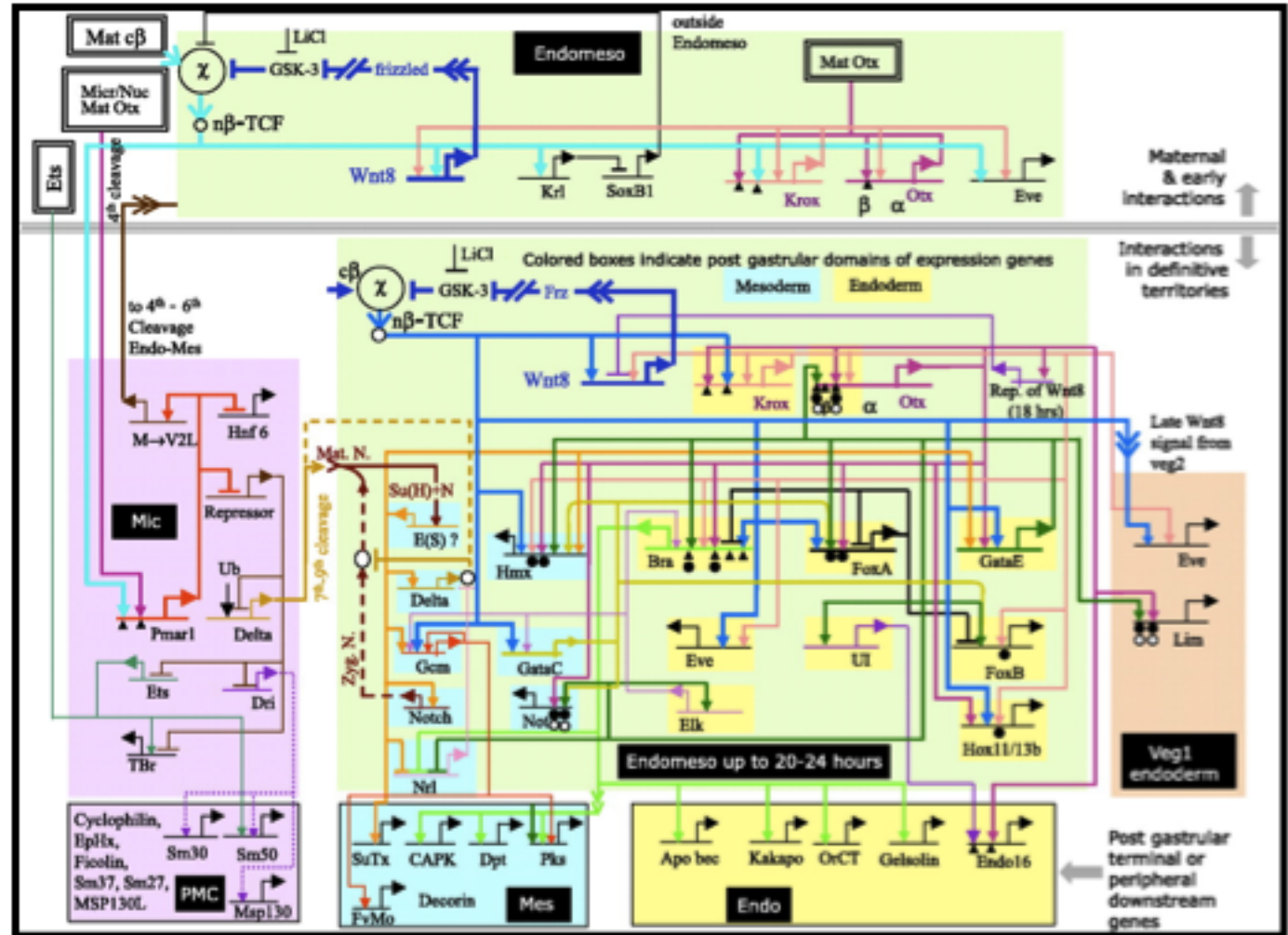

Genetic Networks Programming Early Sea Urchin Development

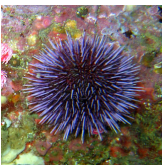
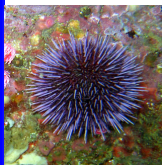

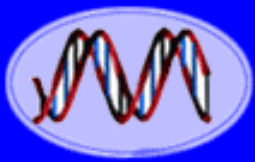

DNA
Genetic Code of Life



Entire Genetic Code
of a Bacteria

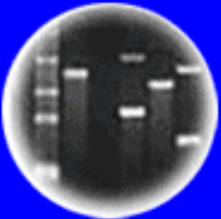

DNA Fingerprinting



Cloning: Ethical Issues
and Future Consequences



Plants of Tomorrow

100 Years Into The Future

1. If the Entire Human Genome is Sequenced?
2. If the Function/Protein of All Genes Are Known?
3. If All the Switches Are Identified & How They Go On & Off From Birth to Death?
4. If We Understand How Genes Are Choreographed & All the Sequences That Program them

What Does the Future Hold?

We Will Know at the DNA Level What Biological Information Programs Life to Death!

What Does This Mean For The Future of Humanity?

Remember - Mendel's Law Were Only Rediscovered 100 Years Ago & Look What We Can Do & Now!